

103282

MAGNUM

OWNER'S MANUAL

**Magnum M-Series Chassis
For Zanzibar and Cheetah**

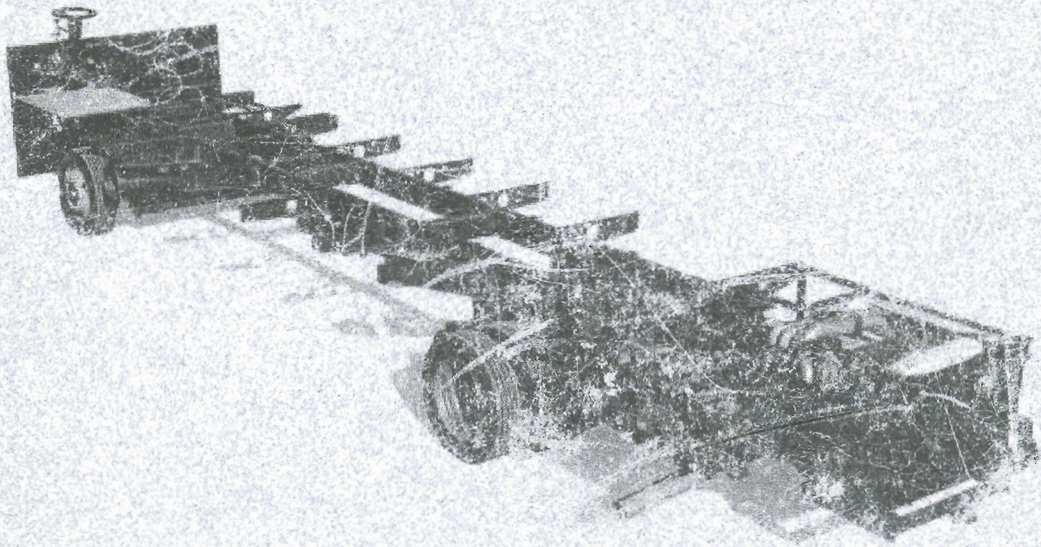

Revision Date: September 15, 2000

The descriptions and specifications in this manual apply to the Zanzibar, and Cheetah motorhomes by Safari Motor Coaches, Inc. Information herein was in effect at the time of its approval for printing. Magnum Manufacturing reserves the right to change specifications or design without incurring obligation. If you have questions regarding this manual, please drop us a line.

MAGNUM

MAGNUM MANUFACTURING

c/o SMC Corporation

PO Box 5639

Bend OR 97708

Warranty (800) 344-6332

<http://www.smccorporation.com/magnum>

<http://www.magnummfg.com>

FOREWORD

Congratulations on your purchase of a Magnum chassis! This chassis is designed and built by Magnum Manufacturing in Harrisburg, Oregon, a division of SMC Corporation.

The purpose of this manual is to provide the owner of the chassis with operation information, an explanation and description of the chassis systems and components, as well as service and maintenance information for those components. This manual consists of three sections; 1) General Information, 2) System Component Description, and 3) Servicing Guidelines. In the Appendices, you will find general information for servicing, such as lubrication charts, fluid capacities, and service part numbers.

Section 1, General Information, contains information including safety precautions, the importance of proper maintenance, and operation of the vehicle. This information is important to ensure the safe operation and maintenance of the vehicle.

Section 2, System Component Description, provides descriptions of the major chassis systems and components in order to help the chassis owner to become more familiar with their chassis. Operation, specifications, and servicing requirements for the systems are given so that the operator will be more comfortable with the operation and servicing of the chassis.

Section 3, Servicing Guidelines, provides servicing information in the form of a maintenance schedule and descriptions of maintenance requirements. This is to help ensure that required maintenance is performed regularly and correctly in order to avoid premature component failures to ensure proper performance of the chassis.

All information contained in this manual is as complete as possible at the time of its publication, and is based on the information available at that time. Product changes may be made at any time and may not be reflected in this publication. Magnum Manufacturing and SMC Corporation reserves the right to make these changes without notice and without obligation. If you have questions regarding this manual, please drop us a line.

TABLE OF CONTENTS

SECTION 1 GENERAL INFORMATION	1-1
CHASSIS MAINTENANCE OVERVIEW	1-1
SAFETY PRECAUTIONS	1-2
VEHICLE OPERATION	1-3
Fueling	1-4
Engine Starting.....	1-4
Engine Stopping.....	1-6
Shifting	1-6
Vehicle Controls.....	1-7
Driving In Adverse Conditions.....	1-9
Fuel Economy	1-12
Jacking and Towing	1-12
Towing A Trailer or Vehicle.....	1-14
Welding	1-15
SECTION 2 SYSTEM COMPONENT DESCRIPTION	2-1
ENGINE	2-1
TRANSMISSION	2-2
SUSPENSION	2-5
STEERING SYSTEM	2-5
Front-End Alignment.....	2-6
AXLES	2-6
Front Steer Axle	2-6
Rear Drive Axle.....	2-7
COOLING SYSTEM	2-8
FUEL SYSTEM	2-10
GAUGES AND INDICATOR LIGHTS	2-12
Gauges.....	2-12
Indicator Lights.....	2-14
SERVICE AND PARK BRAKE SYSTEMS	2-15
ABS Brake Systems.....	2-15
EXHAUST SYSTEM	2-16
AIR INTAKE AND CHARGE AIR SYSTEM	2-16

ELECTRICAL SYSTEM	2-17
TIRES AND WHEELS	2-18
SECTION 3 SERVICING GUIDELINES	3-1
RECOMMENDED MAINTENANCE INTERVALS.....	3-2
Daily	3-2
Weekly	3-2
Scheduled Maintenance	3-3
MAINTENANCE INSTRUCTIONS.....	3-3
Daily Maintenance Descriptions.....	3-3
Weekly Maintenance Descriptions.....	3-6
DIAGRAM A- Front Axle Hub Components and Fill Levels.....	3-7
Scheduled Maintenance Descriptions	3-8
DIAGRAM B- Rear Axle Plug Locations	3-8
DIAGRAM C- Tire Rotation.....	3-11
APPENDICES	I
APPENDIX A -- M-SERIES CHASSIS LUBRICATION POINTS.....	I
APPENDIX B -- FLUID CAPACITIES.....	II
APPENDIX C -- CHASSIS FILTERS AND BELTS.....	III
APPENDIX D -- LUBRICATION AND FLUID SPECIFICATIONS.....	IV
APPENDIX E -- RECOMMENDED TIRE INFLATION PRESSURES.....	V
APPENDIX F -- TYPICAL CHASSIS SERVICE CENTER	VI
APPENDIX G -- ENGINE WILL NOT START TROUBLESHOOTING	VII
APPENDIX H -- FUEL SYSTEM AIR BLEEDING	VIII
APPENDIX I -- CHASSIS FUSE PANEL	IX
APPENDIX J -- MAIN DRIVE BELT DIAGRAM	X
LIMITED CHASSIS WARRANTY	XI

SECTION 1 GENERAL INFORMATION

CHASSIS MAINTENANCE OVERVIEW

Before leaving on your first trip with your new vehicle, take the time to familiarize yourself with your chassis. Read through the owner's manuals pertaining to your chassis and its components, and allow time to look the chassis over in order to locate the chassis components and service points. Refer to Section 3 of this manual, Servicing Guidelines, and become familiar with the daily maintenance checks for your chassis, and perform the daily maintenance; getting into the habit of performing routine maintenance on your chassis will help ensure years of trouble-free operation. Read and understand your Vehicles Owner's Manual as well, as it may contain additional items to check before driving.

Magnum Manufacturing stands behind its products, but it is up to the operator to ensure that the regular maintenance is performed properly. Magnum cannot be responsible for problems with the chassis arising from neglected or improper maintenance.

Just as important as having maintenance performed regularly, is having it done correctly. Use service centers with the proper equipment to service your vehicle and with properly trained technicians experienced in the service and repair of motor home chassis; be familiar enough with your vehicle to inspect the work performed by a service center to ensure that the work has been completed correctly.

Each day before driving and when stopping to re-fuel, go through the daily maintenance checks as outlined in Section 3 of this manual. If operating the vehicle in severe conditions such as extremely dusty environments, city driving or abnormally rough road conditions, it will be necessary to increase the frequency of all maintenance operations.

SAFETY PRECAUTIONS

Magnum Manufacturing can in no way account for all possible circumstances that may result in vehicle damage, bodily injury, or loss of life. However, throughout this manual are listed safety precautions that must be observed in order to complete specific tasks safely and efficiently. While reading procedures in this manual, look for safety precautions that are formatted as follows:

WARNING

As with all mechanical devices, certain safety precautions must be taken when servicing or repairing the chassis. When working on the chassis, always be aware of what you are doing, as well as other individuals who may be in the area. Never attempt to repair or service a component with which you are unfamiliar. Be sure to read the appropriate safety precautions as set forth in this manual.

When performing service or repair procedures as listed in this manual, always look for, read, and fully comprehend any safety precautions as outlined above. In addition, read, understand, and use the following list of warnings. These warnings may not be included elsewhere in this manual, and are essential for the safe service and repair of your chassis.

WARNING

Always place a "Do Not Operate" tag on the engine start switch and vehicle controls when servicing or repairing the vehicle.

Always place the chassis frame on jack stands of suitable capacity when working underneath the vehicle.

Always place wheel chocks at the tires when jacking the vehicle, working underneath the vehicle, or in other circumstances which may cause the vehicle to roll unexpectedly.

Never perform work or service on the electrical system without first disconnecting the batteries.

Always relieve pressure from fuel, hydraulic, air, oil, and cooling systems before servicing or repairing fittings, hoses, and components.

Never work on or around the vehicle with loose clothing or jewelry, and avoid moving parts at all times.

WARNING

Always keep fuels and lubricants away from flame or heat producing components, as they are flammable.

When using the leveling jacks, never raise the vehicle so that the tires are suspended in the air. Always use suitable capacity jack stands in conjunction with the leveling jacks when working underneath the vehicle.

Do not store any items in the battery compartment, electrical bay, generator compartment or any other compartment not intended for storage. Vehicle damage and/or personal injury may result.

When servicing and maintaining the vehicle, be aware that many components of the chassis produce heat, and that contact with these components, as well as their fluids and lubricants can produce serious burns.

When servicing or repairing the vehicle chassis, it is important to use the following steps in order to help ensure that the task is completed safely. Always follow these steps prior to working on the vehicle, unless otherwise noted:

1. Turn the vehicle engine off.
2. Place a "Do not operate" tag on the engine start switches and vehicle controls.
3. Set the vehicle park brake.
4. Place wheel chocks at the vehicle tires.
5. Disconnect the batteries before servicing or performing maintenance on the vehicle or electrical system.

VEHICLE OPERATION

Congratulations on the purchase of your motorhome. You have made a substantial investment of time and money. Now it would be a good idea to invest some time in getting to know your chassis and its components.

M

Please pay particular attention to the maintenance sections, as there are procedures that need to be performed on a regular basis. When you're away from home and out on the road, it's important to be able to carry out these maintenance functions yourself.

Fueling

WARNING

Fuel is highly flammable. Do not refuel while smoking or near open flame or sparks. Always stop the engine when fueling and fill the tank outdoors. Remove the fill cap with caution, as internal pressure may cause fuel expulsion.

In order to ensure easy starts and overall performance, always use clean, good quality fuel in your chassis. Recommended fuel for use in the Caterpillar diesel truck engines is No. 2-D diesel fuel with a low sulfur content (0.05% maximum) and a minimum cetane of 40. Also acceptable are No. 1 grades. When operating the vehicle at higher altitudes or low temperatures, use a fuel with a higher cetane number. Refer to the Caterpillar Operation and Maintenance Manual for more specific fuel recommendations.

Water, dirt, and other contaminants may be introduced into the fuel system while fueling your vehicle. These contaminants can cause damage to the entire engine; always follow the maintenance guidelines in this manual for servicing the fuel filter/water separator to prevent engine damage. Always keep your fuel tank full, especially when storing the vehicle or not driving it for longer than a week; this will help prevent condensation in the fuel tank and the introduction of water in the fuel system.

Engine Starting

WARNING

Do not use ether starting aids to aid in starting the engine as engine damage and/or personal injury may occur. Never attempt to start the engine by "jumping" relays or any means other than using the ignition start switch or the remote start switch. Do not attempt to start the engine if a "Do not operate" tag is placed on the engine start switches or vehicle controls, and ensure that personnel are clear of the engine before starting.

When starting the engine, always use the following procedure:

1. Turn off the vehicle headlights and any other auxiliary equipment prior to starting to ensure that all available battery power will go to the starter motor.
2. Ensure that the park brake is engaged.
3. Turn the ignition switch to the “ON” position.
4. Look at the dash warning and transmission shifter lights; the “CHECK TRANS” light on the transmission shifter should illuminate, as well as the “LOW OIL PRESSURE” and “PARK BRAKE” lights on the dash panel. The “CHECK ENGINE” light should illuminate and then cycle off.

NOTE: If any of the warning lights fail to come on, investigate and correct the cause of the problem. If the “CHECK ENGINE” light remains on, or re-illuminates after starting, the engine ECM may have detected an engine systems fault. Refer to the diagnostics section of the Caterpillar Operation & Maintenance Manual for corrective action. If the transmission “CHECK TRANS” fails to illuminate, or remains on after starting, refer to the transmission Operators Manual for corrective action.

The “AIR INLET HEATER” lamp should also illuminate for 2 to 30 seconds, depending upon the engine coolant and inlet air temperatures. Wait to start the engine until the “AIR INLET HEATER” lamp goes off. Starting the engine with the “AIR INLET HEATER” illuminated may result in excessive white smoke at start-up.

5. Without pushing or holding the throttle down, turn the ignition switch to the “START” position and crank the engine. The electronic controls on the engine will automatically deliver the correct amount of fuel to the engine for starting.

NOTE: To avoid starter motor damage, do not crank the engine for more than 15 seconds at one time. If the engine fails to start, wait two minutes before attempting to start the engine again.

6. Release the ignition switch to the “ON” position immediately after the engine starts.

NOTE: Observe the engine oil pressure warning light and gauge to ensure that oil pressure is at an adequate level after starting. Oil pressure at start-up should be above 20 psi, and will vary depending upon engine temperature and oil viscosity. Turn the engine off immediately if the engine oil pressure does not register within 15 seconds after the engine starts. If oil pressure does not register, investigate the cause and take corrective measures.

If the engine fails to start after following these procedures, see Appendix G, “Engine will not start troubleshooting”.

M

7. Allow the engine to idle about 3 minutes, or until the coolant temperature begins to climb before operating the vehicle.

Engine Stopping

After running the vehicle at highway speeds with a load, it is necessary to allow the engine temperatures to stabilize prior to shutting the engine off. Doing so will help prevent accelerated wear of certain engine components, and prevent overheating.

When stopping the vehicle, place the transmission in neutral (N), set the parking brake, and allow the engine to idle for three minutes. After the engine has idled for this amount of time, turn the ignition switch to the “OFF” position to stop the engine.

Shifting

(For more information on the operation, maintenance, and description of the Allison World Transmission, refer to Section 2 and 3 of this manual, and also the Transmission Operator’s Manual.)

The Allison MH Transmission is a six-speed automatic transmission controlled by an Electronic Control Unit (ECU) located in the electrical bay at the driver’s side front of the vehicle, and a shift pad for transmission operation. The push button selector is used to select driving ranges, and each switch pad is labeled according to its function:

NEUTRAL (N)- Use this selection for starting the engine, checking vehicle accessories, and idling. The ECU should automatically select neutral when the ignition key is turned on, and should not allow the engine to start in any gear selection other than neutral. Seek service immediately if these conditions are not met. Always place the transmission in neutral before turning off the engine.

WARNING

Always set the parking brake when the transmission is in neutral. The transmission does not have an internal lock to prevent the vehicle from rolling when the transmission is in neutral.

Never leave the vehicle unattended with the engine running or the parking brake off; sudden vehicle movement may occur resulting in property damage or injury.

Never coast the vehicle with the transmission in neutral; this may result in transmission damage and loss of available engine braking.

REVERSE (R)- To shift into reverse, the vehicle must be completely stopped; the transmission will not shift otherwise. Locate and press the “R” pad on the shift selector. The transmission will engage and the display will register “R”.

DRIVE (D)- To shift into drive, locate and press the “D” pad on the shift selector. The transmission will automatically up shift as the vehicle speed increases, and downshift as the vehicle speed decreases. The indicator on the shift selector will display the highest gear available.

SELECTING GEARS (↓ ↑)- The arrow pads on the shift selector can be used to select different gears to meet driving conditions. Press the down arrow pad on the shift selector to shift to a lower gear, and the up arrow pad to select a higher gear. When using the arrow pads to select different gear ranges, the select indicator will show the highest gear that the transmission will shift to. The transmission may, however, shift to a higher gear if damage to the engine or transmission is possible due to engine over speed, regardless of the gear selector setting.

MODE (MODE)- The mode button on the shift selector can be used to change the shift patterns in order to enhance the fuel economy of the vehicle. With the mode off, the transmission shifts are delayed until a higher engine RPM is attained, resulting in an improvement in overall performance. By turning the mode on, the transmission will shift into the next higher gear sooner, allowing for smoother shifts and improved fuel economy. The mode can be turned on or off at any vehicle speed in order to meet driving conditions. It is recommended to drive the vehicle with the “mode” function on whenever you are driving in conditions in which you also use the cruise control. This will help optimize the fuel economy of the vehicle.

Vehicle Controls

CRUISE CONTROL

WARNING

Never shift the transmission into neutral when using the cruise control; doing so may cause the engine to over speed and may cause damage to the engine.

Never use the cruise control in icy, wet, snow, or other slippery conditions, or in congested traffic; doing so may lead to loss of control of the vehicle and impaired reaction time to obstacles.

The cruise control of your vehicle can perform several different functions.

M

They can be used to maintain the speed of the vehicle while traveling; the idle speed of engine can be temporarily set at a higher rpm using the switches; and diagnostic information of the engine can be obtained with the cruise control switches.

The cruise control allows you to set and maintain the speed of your vehicle when the vehicle speed is above 25 mph. The cruise control will not work while the brake pedal is depressed or if the exhaust brake switch is on. Using the cruise control switches, you are also able to set the idle speed of the engine above the governed idle speed. To disengage the cruise control or controlled fast idle, turn the on/off switch to the off position, press on the brake pedal, or activate the exhaust brake. The cruise control switches are located on the driver's side console to the left of the driver's seat.

On/off switch-This switch must be in the "ON" position to engage the cruise control or controlled fast idle. Placing the switch in the "OFF" position with the cruise control or controlled fast idle engaged will cancel them.

Set/decel switch-Use this switch to engage the cruise control and controlled fast idle. The set function of the switch will set the cruise control at the desired vehicle speed. As soon as you reach the vehicle speed you wish to travel at, momentarily engage and release the switch, and the vehicle speed will be maintained. Engaging the switch while the cruise control is set will slow the vehicle speed. Engage the switch until the vehicle slows to the desired speed, and release. Momentarily engaging and disengaging the switch will decrease the vehicle speed by one mph.

Use the controlled fast idle function to set the engine rpm at a desired rpm above that of the governed idle speed while the vehicle is parked. Depress the throttle until the desired engine speed is reached, and engage and release the set/decel switch.. This will hold the engine speed selected until the on/off switch is turned off, or the brake is depressed. Engaging the switch while the controlled fast idle is set will decrease the engine speed.

Resume/accel switch-Use this switch to return to a previously set vehicle speed after the cruise has been canceled by depressing the brake pedal, engaging the exhaust brake, or turning the on/off switch to the "OFF" position. After the vehicle has slowed to avoid obstacles and the roadway is clear, momentarily engage and release the switch, and the vehicle will return to the previously set speed. While the cruise control is engaged, depressing this switch will increase the set speed of the vehicle. Momentarily engaging the switch will increase vehicle speed by one mph. While in the controlled fast idle mode, the use of this switch will increase the idle speed.

EXHAUST BRAKE

Your vehicle is equipped with an exhaust brake, which uses engine compression to help slow the vehicle when activated. The brake is very effective in slowing the vehicle when descending grades, slowing for curves, and decelerating prior to stopping. The exhaust brake is activated using a two position switch with an "OFF" and "ON" position.

The exhaust brake is controlled by the engine electronics, which will not allow the exhaust brake to activate unless the throttle is in the “no fuel” or released position. If the switch is in the “ON” position, the brake will activate as soon as the throttle is released.

If the exhaust brake is activated while the cruise control is in use, the cruise control will automatically be deactivated. To reactivate the cruise control, return the exhaust brake switch to the “OFF” position, and reset the cruise control.

WARNING

Never rely on the exhaust brake to bring the vehicle to a complete stop; it is not intended to be used for this purpose.

Do not use the exhaust brake when the road surfaces are slippery; loss of vehicle control can result.

STEERING COLUMN

The steering column is equipped with both tilt and telescope functions in order to adjust the steering wheel to a comfortable driving position. To adjust the tilt of the steering column, pull the lowest lever on the left-hand side of the column toward you. The column can then be moved to the desired position; releasing the lever will lock the column into place. You can use the column tilt for convenient entry and exit of the driver’s chair.

To telescope the steering column, push the same lever away from you, and extend or retract the column pushing the steering wheel down or pulling it toward you to the desired position. Release the lever to lock the column into place.

Driving In Adverse Conditions

DESCENDING GRADES

When descending a long grade, use the braking force of the engine and exhaust brake to maintain a safe, slow speed. Do not rely on the service brakes themselves to slow the vehicle while descending long grades; over-use can result in the brakes to over-heat and loss of brake effectiveness can result.

Before descending a grade, downshift the transmission to a lower gear and use the engine to slow the vehicle. You should enter a grade at the same speed at which you wish to be traveling when you reach the bottom. Monitor the vehicle speed as you descend the grade.

M

If the vehicle begins to accelerate as you proceed down the grade, or it is necessary to slow the vehicle more, activate the exhaust brake. If it is necessary to use the service brakes for additional braking, use a moderately heavy pressure on the brake pedal to reduce the vehicle speed to the speed which you wish to be traveling at, and then release them. Allow the vehicle to accelerate approximately 5 mph over the speed that you wish to travel at, and then slow the vehicle again with the service brakes. "Pumping" and riding the brakes is not recommended when descending a grade or a hill, as the brakes can overheat. Only use the service brakes when it is necessary, and rely on the braking force of the engine and exhaust brake to slow the vehicle.

WARNING

Never allow the engine to exceed 2900 rpm as engine damage can result.

COLD WEATHER STARTING AND OPERATION

WARNING

Do not use ether cold starting aids to aid in starting the engine as engine damage and/or personal injury may occur.

Starting and operating your vehicle during cold weather necessitates extra care and consideration of your vehicle. Use the following guidelines and refer to the Caterpillar Operation & Maintenance Manual to help ensure safe, trouble-free operation of your vehicle:

1. When operating the vehicle below 32 degrees F, engine starting can be enhanced by a engine block heater or other means to warm the engine oil. This will help prevent misfiring and white smoke during starting.
2. Always follow the recommended oil, fuel, and coolant specifications as outlined in the Caterpillar Operation & Maintenance Manual. Proper oil viscosity and coolant mixes will help ease engine starting and help to avoid engine damage.
3. Check the air inlet and filter daily, or as necessary when driving in snow conditions.
4. Your vehicle batteries work overtime during the hours of winter darkness; check and service the batteries frequently to help ensure trouble-free starts.
5. Allow the engine to idle until it warms sufficiently for operation; utilize the fast idle to warm the engine faster, and wait to operate the vehicle for at least 3 minutes or until the coolant temperature begins to climb.

6. Start out slowly with the vehicle to allow the transmission and axle lubricants time to circulate and warm before putting them under full load.
7. *After driving over roadways which may have been “salted” in order to melt snow and ice on the road surface, be sure to rinse the chassis and vehicle thoroughly with clean water to help prevent corrosion of the chassis.*

When driving the vehicle on slippery road surfaces such as ice, snow, or wet conditions, always decrease your speed and allow for extra stopping room. Always use additional traction devices such as tire chains when encountering snow or ice conditions. Avoid quick direction changes and press the brakes steadily and evenly when stopping, and refrain from using the cruise control and Jake Brake on slippery road conditions, as loss of vehicle control may result.

WATER CROSSING

WARNING

Never attempt to drive through water deeper than one foot or of unknown depths, or water which has a noticeable current, as vehicle damage and/or personal injury may occur.

Avoid driving through standing water if at all possible, especially if the water is over one foot deep, or if you are uncertain of the water depth. Water, mud, and other contaminants can enter the running gear of the chassis, resulting in premature wear and failure. Never drive through water that has a noticeable current. If it is unavoidable to drive through water, follow these precautions:

1. Drive slowly with the transmission in low gear.
2. Apply the brakes lightly to keep the brake pads in contact with the rotors. This helps prevent mud and sand from contaminating the brake pads.
3. After leaving the water, maintain light pressure on the brakes for a short distance in order to heat the brakes so that they will dry.
4. After ensuring that there is not a vehicle behind you, make a test stop with the brakes in order to check the service brake's effectiveness. If the brakes have not returned to normal, continue to dry and test them until they have regained their effectiveness.
5. At the earliest opportunity, have all lubricants and wheel bearings checked to ensure that they have not been contaminated with water and/or mud.

Fuel Economy

Many factors contribute to the amount of fuel consumed during driving. Driving styles, wind resistance, terrain, vehicle weight, and engine driven accessories are some of the factors that can affect the fuel economy. Use the following guidelines to help increase fuel efficiency:

1. When starting out, use smooth, easy starts by gradually increasing speed, rather than using excessive throttle and accelerating quickly.
2. While operating the vehicle, keep the engine at a low to mid rpm range of 1400 to 2000 rpm. Doing so will use less fuel than operating at higher rpm.
3. While driving in rolling hills, avoid downshifts when going uphill, and use the downhill grades for accelerating, rather than the throttle.
4. Avoid extended idling to allow the engine to warm; only wait long enough for normal oil pressure to register and the engine coolant temperature gauge to begin to climb. Excessive idling, (longer than 5 minutes), can cause carbon build-up and/or diesel slobber which can be detrimental to the engine. If it is necessary to idle the engine for periods longer than 5 minutes at a time, increase the engine rpm to 1000 rpm to help prevent slobber and carbon build-up.
5. Operate the transmission with the MODE function on whenever possible; this allows for earlier shifts and enhanced fuel economy.
6. Follow the maintenance schedule for your chassis; proper maintenance will lead to enhanced fuel economy, vehicle performance, and longevity.

Jacking and Towing

WARNING

Never work or get beneath the vehicle when not supported by jack stands of suitable capacity.

Always use chock blocks on a vehicle that is being jacked, or that the park brake has been disabled.

Always comply with all state and local laws when towing a vehicle.

Never tow a vehicle in such a manner that may cause property damage, or pose a hazard to personnel, bystanders and other motorists.

WARNING

Never jack the vehicle with the leveling system so that the tires are suspended in the air. Doing so may result in property damage or personal injury.

When performing maintenance or repairs to the chassis, it will become necessary on occasion to lift the vehicle in order to perform such work. It is recommended that only a qualified and experienced mechanic be called upon to make repairs that require the vehicle to be jacked, such as replacing a flat tire.

While it is possible to jack the vehicle using the coach leveling system, it is recommended to use a separate jacking device to do so, as the leveling system is not designed for this purpose. With this in mind, please read and follow the following precautions to help ensure safe jacking of the vehicle:

1. Park the vehicle on a hard, level surface and set the park brake before attempting to jack the vehicle.
2. Always use jacking devices and jack stands of a suitable capacity to safely hold the vehicle.
3. Use chock blocks on the front and rear wheels opposite the side being jacked to prevent the vehicle from rolling.
4. Never jack the vehicle with the leveling system so that the tires are suspended in the air.
5. When working underneath the elevated vehicle, always place jack stands of suitable capacity underneath the chassis.
6. While working underneath the vehicle when it is suspended on the leveling system, place a "Do not operate" tag on all leveler controls, and remove the keys from the ignition in order to help prevent the unauthorized use of the controls. Place jack stands underneath the elevated vehicle.

When it is necessary to have the vehicle towed, always be sure to request a tow truck of suitable capacity, and check with the tow truck operator when they arrive to ensure that the tow truck is of adequate capacity to safely tow the vehicle. Attempting to tow the vehicle with an inadequate tow truck can result in damage to the vehicle and/or unsafe conditions. Always use a fixed tow bar when towing the vehicle.

When having the vehicle towed, it is necessary to remove the driveline from the chassis. Always place chock blocks on a vehicle that has had the driveline removed; the removal of the driveline will disable the park brake. Use the following steps to help ensure the safe removal of the vehicle driveline:

1. Place chock blocks at the tires to prevent unexpected movement of the vehicle.

2. Place the transmission in neutral, and release the park brake.

NOTE: Prior to removing the driveline, attempt to rotate the driveline to ensure that the park brake is released at the brake itself. If it is not released, use the following steps to release it:

Air pressure in the vehicle system must be at least 70 psi to release the park brake. If the vehicle will run, build-up air pressure until there is adequate pressure to release the park brake. Have someone watch the brake mechanism at the driveline to ensure that the brake mechanism releases. If the brake mechanism still fails to operate, seek additional assistance to correct the problem.

If the engine will not run and adequate pressure is not present, it will be necessary to add air to the system from an outside source. This can be done by connecting an airline with the proper adapter to the air system in order to fill the air system. If the park brake mechanism still fails to operate, seek additional assistance to correct the problem.

3. After the park brake is released, remove the fasteners holding the driveline in place.

Towing A Trailer or Vehicle

WARNING

NEVER exceed the rated hitch capacities of your vehicle, or exceed the weight limits of your vehicle. Doing so may result in property damage and/or injury, and void any warranty claims resulting from overloading.

Towing puts extra strain on your vehicle's engine, drive train, brakes, tires, and suspension. With this and the safety of yourself and others in mind, be sure to match the towed load to the vehicle as follows:

The Gross Combined Weight Rating (GCWR) and Gross Vehicle Weight (GVW) determine the towing capacity. If the GCWR is exceeded, serious damage to the drive train may result, and safety may be compromised. Subtract the GVW (the weight of the vehicle plus fluids and stored goods — or the “payload”) from the GCWR (which is the total weight this vehicle can safely motor) to determine the acceptable weight this vehicle can tow. Do not exceed the rated hitch capacities of 5000 pounds towing weight and 500 pounds hitch weight when determining your towing capacity.

Make sure the towing equipment is properly and safely attached to your vehicle. Check to see that the tires are properly inflated and always use a safety chain to provide a backup for the hitch.

The tongue weight of the trailer should be approximately 10 to 15 % of the loaded trailer weight for best handling. Heavy trailers (over 2000 lbs.) should have trailer brakes hooked up, and is a requirement in some states; check your local laws.

Adjust your driving habits to provide for the extra length of the trailer. When turning, drive slightly beyond the normal turning point before steering in that direction. Descend hills at a slower speed than usual, and avoid sudden braking.

Welding

It is advised that only qualified, experienced technicians weld on the chassis. Improper welding procedures and materials may weaken the assembly or result in unforeseen damage that will occur in the future. Unauthorized modifications or repairs to the chassis will result in a forfeiture of warranty coverage.

Due to the sensitive nature of the electronics on your chassis, it is necessary to disconnect the following electrical devices as described before any welding is performed:

1. Disconnect all ground cables and wires from the negative posts of all batteries.
2. Disconnect all three terminal plugs from the engine Electronic Control Unit located on the passenger side of the engine block.
3. Disconnect both plugs from the Allison Electronic Control Module located in the Electrical Bay at the driver's side front of the vehicle.

When welding, always place the ground clamp as close to the area to be welded as possible.

SECTION 2 SYSTEM COMPONENT DESCRIPTION

This section provides the chassis owner with descriptions of major chassis systems and components in order to help the chassis owner to become more familiar with the chassis. Operation and specifications for the systems are given so that the operator will be more comfortable with the operation and servicing of the chassis. Before performing service on the vehicle, read all instructions in Section 3 of this manual, information pertinent to individual components of the chassis contained in the owner's packet, and all safety warnings and precautions.

ENGINE

Refer to the Caterpillar Operation & Maintenance Manual for additional information concerning the operation, description, maintenance, and warranty information for your engine.

Your vehicle is equipped with a Caterpillar 3126 diesel engine. This 6-cylinder in-line engine utilizes an electronically controlled, hydraulic actuated unit injector system to supply fuel to the cylinders. This electronic fuel control allows for precise fuel delivery resulting in efficient operation, as well as built-in diagnostics to monitor engine operation.

The engine electronics also enable the use of programmable monitoring features that may cause limited engine power/vehicle speed when certain conditions are met. These features limit the operation of the engine when conditions that may damage the engine are encountered. These conditions may include such events as high coolant temperature.

When the engine electronics encounter such a condition, it limits the amount of power produced by the engine to help ensure that no damage occurs. It is possible however, for the engine to be damaged if corrective action is not taken immediately if such a condition exists. Unnecessary operation of the vehicle while in the limited operation mode may result in a forfeiture of warranty coverage.

M

If a sudden loss of power is noticed in conjunction with the “CHECK ENGINE” light illuminating, pull to the side of the road as soon as it is safely possible, evaluate the situation, and take corrective action. Utilizing the information in the Engine Diagnostics section of this manual will help to determine what action is necessary.

ENGINE DIAGNOSTICS

The engine diagnostics will notify the operator of any deviations from the programmed limits of the engine through the “Check Engine” lamp in the dashboard. Should a system component with the engine develop a deviation, the “Check Engine” light will illuminate, and a diagnostic code will be logged and stored in the system memory. These codes may be accessed using either a service tool or by using the cruise control switches to read the diagnostic flash code.

To access the diagnostic flash code using the cruise control switches, perform the following actions:

1. Turn the ignition switch to the “ON” position.
2. Turn the cruise control power switch to the “OFF” position.
3. Engage and hold either the cruise control “Set” or “Resume” switch until the “Check Engine” Lamp illuminates and begins to flash.
4. The lamp will flash a number of times followed by a pause and a second series of flashes. Count the number of flashes to determine the two digit flash code. **EXAMPLE:** The lamp flashes four times followed by a two second pause, and then one more flash indicating a flash code of 41-Vehicle Over speed Warning.
5. A code of 55 indicates no faults found. After noting any flash codes present, refer to the Engine Diagnostics section of the Caterpillar Operation and Maintenance Manual for code description and necessary action.

TRANSMISSION

WARNING

Always set the parking brake when the transmission is in neutral. The transmission does not have an internal lock to prevent the vehicle from rolling when the transmission is in neutral.

Please refer to the Allison World Transmission Operator's Manual for additional information concerning the operation, description, maintenance, and warranty information for your transmission.

The Allison MH 3000 World transmission in your vehicle is an electronically controlled automatic transmission. The electronic controls of the transmission allow for several features including the ability to "learn" in order to optimize shift points and also to check the fluid level of the transmission electronically.

The World transmission constantly monitors engine and transmission information while in operation so that it can evaluate operating conditions. The transmission uses this information to calculate optimum shift points for smoother shifting and to optimize fuel economy. The transmission's electronic control stores this information, and uses it to adapt to your own particular driving style. A new or re-calibrated control unit will normally shift poorly until it "learns" the necessary information it requires for optimizing shift points. If a change is made in the control unit on your coach, simply drive the vehicle as you normally would, and it will begin to function normally in short order.

Changes in your vehicle can also affect the shift quality of the transmission. For example, if you normally tow a heavy vehicle behind the coach, and operate the coach without this tow vehicle, you may notice a difference in the way the transmission shifts. If you do, simply drive the coach normally, and the transmission will quickly adapt to the change in weight.

When parking the vehicle, always set the park brake to prevent the vehicle from rolling. The Allison World transmission differs from most car transmissions in that it does not have an internal locking device to prevent the vehicle from rolling when parked. The park brake must be applied to prevent the vehicle from rolling.

The two most critical maintenance procedures that you as the owner are responsible for in respect to the transmission are ensuring adequate transmission fluid levels and following the recommended fluid and filter change intervals. Proper fluid levels and maintaining proper fluid and filter change intervals will help to ensure that the transmission will provide long service life.

CHECKING TRANSMISSION FLUID LEVEL

WARNING

Never operate the vehicle unless the transmission fluid level has been verified as being adequate. Operating the vehicle with insufficient or excessive fluid levels can cause damage to the transmission.

The transmission used in this chassis is a "deep sump" transmission. There are two ways of checking the fluid level of the transmission.

The transmission dipstick gauge at the rear of the coach, and using the transmission electronics to check the fluid level. While both methods are acceptable for determining the fluid level, Magnum recommends using the electronics of the transmission to determine the fluid level, as it is the easier and most accurate of the two methods.

With both methods, the transmission must be at operating temperature with the engine idling, the transmission in neutral, and the vehicle parked on a level surface to obtain an accurate reading. The transmission electronics will not even display a fluid level unless the transmission is at operating temperature (above 142 degrees). Although the dipstick gauge for the transmission has “cold” markings on it, this should only be used to determine if the transmission has sufficient fluid in it to operate the transmission to warm it up to do a hot fluid check. The level of the transmission fluid should be checked daily, which is performed easiest after the day’s travels are completed. This ensures that the transmission is already at operating temperature when checking the fluid level.

FLUID AND INTERNAL FILTER CHANGE RECOMMENDATIONS

After the transmission has operated for 5,000 miles, it is time for the initial fluid and filter change. Once this initial change has been done, the filter and fluid must be changed every 25,000 miles or 18 months, whichever comes first, from the mileage or date of the initial change. This will ensure that the transmission fluid remains clean and “fresh” to help ensure proper operation of the transmission. In severe service conditions, it may be necessary to change the fluid and filter more often. Always change the filter and fluid if any evidence of dirt, discoloration, or strong odor is present with the transmission fluid.

DEXRON III and DEXRON II fluids are recommended for on-highway applications. If operating in extreme cold temperatures, (below -17 degrees Fahrenheit) pre-heating the transmission is required before operation.

THE “CHECK TRANS” or “DO NOT SHIFT” LIGHT

In order to protect the vehicle, operator, and transmission, the transmission electronics will limit operation of the transmission under certain conditions. When this happens, the electronics will restrict shifting of the transmission and the “DO NOT SHIFT” or “CHECK TRANS” light will illuminate in the dash. While the ignition switch is still on, the transmission will generally not allow itself to be shifted from a forward to reverse gear, and will limit upshifts and downshifts. Turning the ignition switch off may cause the transmission to shift automatically to neutral and remain there regardless of operator input.

If this happens, the transmission can be operated for a short time in order to seek assistance, or to locate a safe parking area. Always seek assistance as soon as possible when the “DO NOT SHIFT” / “CHECK TRANS” light is activated.

A “DO NOT SHIFT” condition normally will cause a diagnostic code to be logged and stored in the electronics. These can be accessed using the instructions found in the Allison Operator’s Manual.

If the condition which caused the “DO NOT SHIFT” to illuminate was temporary, it may be possible to “clear” the stored code and continue normal operation. This can be done by following the instructions in the Allison Operator’s Manual.

SUSPENSION

The B.F. Goodrich Velvet Ride suspension system (VR²) incorporates rubber torsion springs for the suspension system. This is done by binding two steel tubes together, one inside the other, with a rubber compound to react to shock and vibration from the road surface. The outer tube is mounted directly to the axle, while the inner tube is attached to the frame through a “hinged” arrangement. Adjustment shims are located at the frame attachment in order to adjust the vehicle height if necessary. These shims should not be adjusted unless necessary, as doing so will affect the geometry of the drive train, suspension, and steering and may cause damage to the vehicle if operated higher or lower than design parameters.

Gas charged shock absorbers are used to dampen suspension travel while both a front and rear sway bar are installed to minimize vehicle sway. The front of the vehicle also utilizes a radius rod attaching the axle to the chassis frame on the driver’s side to help stabilize the front axle.

STEERING SYSTEM

The power steering system uses hydraulic power from the engine to provide full-time hydraulic steering, instant response, and the ability to help absorb road shock at the steering wheel. The steering system is comprised of the steering gear, steering column, hydraulic system and steering linkages to the front axle. When input to the steering system is supplied by the vehicle operator, the rotational input of the steering shaft causes hydraulic power from the hydraulic pump on the engine to move the sector shaft of the steering gear. This movement of the sector shaft is then transferred to the front axle and tires through the steering linkages.

While driving your vehicle, be aware of any changes in the feel of your steering system, and have the system checked if you notice any apparent differences in the system. While it is normal to hear some noise from the steering, especially when the steering is at it’s maximum turn, investigate any unusual or loud noises that occur, beginning with the level of the hydraulic fluid level. Traveling at slow speeds over rough surfaces may cause a “clunking” noise to emanate from the steering column, but if noise is heard on smooth surfaces while turning back and forth sharply, the cause should be investigated.

M

Shimmy and looseness should be investigated and corrected as soon as possible. If any looseness is felt in the steering, the steering linkages can be observed while someone turns the steering wheel left and right. Watch the linkages for any evident play or rough interaction between components to help pinpoint a problem. Have the steering system checked for damage after a severe impact, such as striking large potholes or curbs, and front-end collisions. Observe the alignment of the steering wheel spokes; a change in the alignment may indicate damage to the steering components or suspension.

Maintenance for the system entails adequate lubrication of the system, as well as hydraulic fluid level checks and replacement. Grease zerks for the steering system are found on the both ends of the drag-link (the bar connecting the steering gear to the axle), and at the output shaft for the steering gear. These points should be lubricated every 6 months or 5,000 miles with grease meeting NLGI 2 specifications. Maintenance requirements for associated steering components are covered in the section for the front axle.

Maintenance requirements for the hydraulic system include fluid level checks, fluid replacement, and inspection. The level of the fluid in the reservoir, located at the chassis service center, should be checked daily to ensure adequate levels for operation. The fluid level should be maintained at the bottom of the fill neck. DEXRON II is recommended as a fill and top-off fluid.

Fluid changes should be performed every 18 months or 15,000 miles, whichever comes first. During the fluid change interval, also perform an inspection of all hydraulic lines for abrasions, and all fittings for leaks.

Front-End Alignment

Due to driving conditions and road hazards, we cannot be responsible for front-end alignments after the vehicle has left our factory. Your vehicle has been aligned to very strict standards while at the factory. The alignment can change, however, once the vehicle is fully loaded. It is recommended that a front-end alignment be performed on your vehicle after you have taken possession and loaded your vehicle. In the Appendices you will find the alignment specifications for your vehicle on the lubrication chart.

AXLES

Front Steer Axle

The front steer axle on your vehicle is an I-beam axle design made of forged, heat-treated alloy steel. Pivots for the axle ends are constructed using an inclined king pin configuration, which are supplemented with steel tapered roller thrust bearings which carry the front vehicle weight.

The front wheel bearings utilize the oil bath (wet) system, which does not require regular grease packing. Maintenance for the wheel bearings consists of weekly oil level checks to ensure adequate lubrication. Inspection of the wheel bearings for wear should be performed any time that the hubs are removed from the front axle. A description of proper lubricant levels is covered in the “Maintenance Instructions” section of this manual.

Lubrication of the front axle is critical in order to avoid premature wear of the king pin assemblies and other components. Grease zerks are located at the king pin assemblies (two on each side of the axle), and one grease zerk on each end of the tie rod. These points require lubrication every 6 months or 5,000 miles with grease meeting NLGI 2 specifications.

Rear Drive Axle

Your vehicle’s rear axle is a single reduction axle consisting of a hypoid pinion and ring gear set and beveled differential gears. The differential carrier can be removed from the axle housing as a unit in order to perform repairs.

All power from the engine to the rear tires to move your vehicle is transferred through the rear axle. For this reason, it is important that maintenance be performed on the axle as required to avoid premature wear of the gears and bearings in the axle.

There are two types of gear oil that may be used in the rear axle. Petroleum gear oil meeting MIL-L-2105D specifications, which is what is used in chassis production, is a “standard” gear lubricant which requires an initial change once the vehicle has operated for 1,000 miles, and subsequent change intervals at 100,000 miles or 12 months, whichever occurs first. Synthetic gear oil meeting MIL-L-2105D specifications may also be used in the rear axle, with an initial change at 1,000 miles, and a change interval of every 250,000 miles thereafter.

During lubricant change, especially, the fine metal particles will be observed clinging to the magnetic fill and drain plugs of the axle. These particles are normal wear particles from the axle components, but they will cause faster than normal wear of the axle components if allowed to circulate through the lubricant. For this reason it is recommended that the magnetic plugs be tested, if not replaced, at each lubricant change when petroleum-based lubricants are used, or every 100,000 miles if synthetic lubrication is used. These plugs should have sufficient magnetic strength to pick up a 1.5 lb. weight of low carbon steel. Never replace a magnetic plug with a non-magnetic “pipe plug” as they will not keep the lubricant clear of metal products or seal properly.

The level of lubricant in the rear axle should be checked every 2,500 miles or 3 months, whichever comes first. This will ensure adequate lubricant in the axle for proper operation.

When checking or changing the lubricant, always ensure that the axle is not “hot”, as the oil temperature may be 190 degrees or hotter, and can easily cause severe burns.

M

Follow the recommendations in the “Maintenance Instructions” of this manual when changing or checking the lubricant level.

COOLING SYSTEM

The cooling system consists of a rear-mounted radiator, a direct-drive fan, an integral transmission cooler, and a charge air cooler which is mounted to the radiator. Steel tubes and radiator hoses allow engine coolant to flow between the radiator and the engine. This cooling configuration draws air from the engine compartment, through the radiator and out the rear of the vehicle. These components all work together to ensure that all chassis systems maintain proper operating temperatures, and are inter-related; a problem with one component may cause problems with an entirely different system.

After the engine reaches proper temperature the water regulator or (thermostat) on the engine opens and allows coolant to flow through the upper radiator hose and into the radiator. The coolant is cooled in the radiator and flows back to the engine through the lower radiator tube.

The charge air cooler or (Inter-cooler) is mounted on the inboard side of the radiator, cools the intake air for the engine after it has passed through the turbocharger. This is necessary due to the heat generated as the intake air is pressurized, and subsequently heated, as it passes through the turbocharger.

Proper maintenance of the cooling system is very important, as all components work together to keep the engine, transmission, and hydraulics operating at the proper temperatures.

One neglected component could result in cooling problems with one or all of the main drive train systems. Maintenance of the cooling system includes maintaining the engine coolant at a proper level. With the correct mixture of coolant and additives, inspection of cooling system components, flushing the engine coolant system with approved cleaners, and ensuring that the exterior of the radiator and other external coolers are kept clean and free of debris.

WARNING

Never remove the coolant cap when the engine coolant is hot. Let the system cool prior to removing the cap. If the cap is removed when the engine coolant is hot, steam and hot coolant will be expelled from the system that will cause severe burns.

The engine coolant level should be checked on a daily basis to ensure that it is at the proper operating level. At the rear of the vehicle is a black steel tank mounted over the radiator. This “surge tank” is where the coolant level is checked, and is where to add coolant if necessary.

Maintain the coolant level of the surge tank so that the level of coolant is within the sight glass when the engine is “cold”, or when the cap is removed after the engine has cooled. Do not attempt to remove the cap when the engine is hot.

Do not attempt to remove the cap on the surge tank when the engine is hot! If the addition of coolant is necessary, simply remove the cap from the surge tank and add the proper mixture of coolant to the system until it reaches the proper level. Be aware that adding straight water or anti-freeze to the system will create an imbalance of the coolant mixture in the system. While adding small amounts occasionally will not affect the mixture greatly, large amounts (1/2 gallon) or frequent “topping-off” will.

Three components are necessary for the proper coolant mixture for the engine: clean water, glycol (ethylene or propylene), and additives. The water in the coolant system serves as the “base” for which the coolant is made of. It is critical to use as pure of water as possible in the coolant system as salts and other minerals in the water can solidify in the cooling system causing scaling and “clogging” of the radiator. Distilled or deionized water is recommended for use in the cooling system in order to avoid these problems. If these are unavailable, a chart located in the Caterpillar Operation & Maintenance Manual shows the minimum acceptable requirements for cooling system water.

Usually in the form of ethylene glycol or propylene glycol, Glycol provides an increased boiling point of the coolant, increases freeze protection and helps prevent water pump cavitation. Cavitation is defined as air bubbles in the coolant mixture. This condition can result in accelerated wear of engine components. While the ratio of water and glycol can be adjusted to meet differing anti-boil and freeze protection, it is recommended that a mixture of 50% water and 50% glycol be used in the system. This 50/50 mixture provides freeze protection to -34 degrees Fahrenheit.

A minimum mixture of 30% glycol and 70% water is required in order to maintain water pump cavitation and corrosion protection, and should never be allowed to be less. Coolant mixture should be checked at every oil change to ensure that an adequate mixture of water and glycol is present in the system.

When purchasing glycol for your vehicle, be aware that many engine coolant/antifreezes are made specifically for gasoline engine applications and contain high amounts of silicates. These formulations with high silicate contents are not recommended for use in your vehicle. Always use the following guidelines when purchasing engine coolant/antifreezes:

1. Use Caterpillar Diesel Engine Antifreeze/Coolant (DEAC) whenever possible.
2. Low silicate coolant meeting ASTM D4985 requirements (this specification should be on the container label) are acceptable for use.
3. Never use any high silicate coolant that meets ASTM D3306, or does not have a specification listed on the container.

M

Additives required for the proper maintenance of the cooling system consist of Supplemental Coolant Additives, or SCAs. SCAs provide corrosion protection for metals, protection from cavitation, and contain anti-foaming agents. While inadequate amounts of SCAs will not provide adequate protection of the system, excessive amounts can also create cooling system problems. Over-concentration of SCAs can result in the additives to drop out of solution and solidify, resulting in the likelihood of scale and sludge to form that can restrict coolant flow. Check the SCA concentration at every oil change, and maintain SCA levels between 3% and 6% concentrations to ensure adequate protection. While several brands of SCA are available, it is recommended to use those available at Caterpillar service centers.

If another brand is used, it must contain silicates and at least 1200 ppm nitrites. Test kits are available from the manufacturer of the SCA to ensure that proper SCA concentration is present. Using a test kit from a different manufacturer of the SCA may result in an inaccurate reading.

The engine coolant system requires draining, cleaning, and coolant replacement every two years or 200,000 miles. This should also be performed any time the coolant is heavily contaminated, foaming of the coolant is observed, or oil/fuel is found in the coolant. This procedure removes small particles, scale, rust, and other contaminants from the system to ensure proper performance. For detailed instructions on this procedure, see the maintenance section in the Caterpillar Operation & Maintenance Manual.

When performing this maintenance, it is also necessary to inspect other components of the cooling system. Have an inspection performed of the surge tank cap seal and have the cap pressure tested, and also replace the thermostat, gasket and seal. The charge air cooler and radiator also requires an inspection for cracks, broken welds, secure mounting, and general cleanliness.

It may be necessary to clean the radiator and external coolers more often under certain conditions. Leaves, twigs, road debris, and other contaminants can block the radiator and cooler fins resulting in reduced cooling system performance. Blockage can vary depending on road conditions, climate, and regional conditions; check the radiator and external coolers weekly for any blockage and clean as required. To clean the radiator and external coolers, compressed air is recommended. In the event that road grime, oil, or inadequate cleaning with compressed air is encountered, a high-pressure washer and degreaser may be used with caution, as excessive pressure can bend the radiator fins.

FUEL SYSTEM

The fuel tank, fuel lines, fuel/water separator, secondary fuel filter, fuel transfer pump, and fuel injectors are the main components of the fuel system. When the fuel transfer pump is operating, fuel is siphoned from the fuel tank through the fuel supply hose to the water/separator located on the service center. Most contaminants that may be present in the fuel are removed at this point.

The fuel passes through the fuel transfer pump, which is a fixed clearance gear transfer pump, and then flows to the secondary filter also located at the service center which removes any remaining contamination in the fuel down to five microns. From the filter, the fuel flows to the injectors, where the ECM controls injection timing and the amount of fuel delivered to the cylinder through the use of an electric solenoid on the injector.

Prevention of problems associated with the fuel system and performance of the vehicle begins with the quality and cleanliness of the fuel used. Fuel contaminated with water, dirt, and even algae can quickly clog fuel filters and cause problems with the fuel system.

Always seek large fueling stations, such as truck stops, which do a large amount of business whenever possible, as the supply of fuel is replenished often.

Always keep the fuel tank full whenever possible, as this helps prevent water condensation from forming inside the fuel tank. This condensation can cause problems in the fuel system not only with the filters, but can also eventually cause corrosion of the fuel tank. Always stop and fill the fuel tank before resting for the night when traveling, and store the vehicle with a full tank of fuel.

Two different grades of fuel may be used in your vehicle: No. 2-D diesel fuel, which is the recommended grade; and No. 1 grades, which are also acceptable. Blends of No. 2-D and No. 1 grades are also acceptable. These fuels should have a minimum cetane number of 40 and be of a low sulfur content (less than 0.05 percent) in order to reduce engine wear and emissions. Under most circumstances, No. 2-D fuel should be used, with the exception of cold weather operation, in which No. 1 grades or a blended fuel should be used. No. 1 grades of fuel have a lower pour point and cloud point than No. 2-D fuel, enabling them to flow through the fuel system easier at lower temperatures. A disadvantage to No. 1 fuels is that they have a lower BTU content than No. 2-D diesel, and will provide less power and consequently poorer fuel economy.

Fuel additives should not be added to the fuel under most circumstances. Always consult your fuel supplier or Caterpillar service center for information on fuel additives should they be necessary.

Maintenance of the fuel system is important, as it supplies the energy with which the engine requires to run efficiently. Poor maintenance of the fuel system can result in poor performance, premature failure of components, and unexpected break downs. Inspect the entire fuel system at oil change intervals for leaks, secure mounting, corrosion, and other problems.

Inspect the fuel/water separator strainer daily, looking for water and other contaminants in the separator. Small amounts of contaminants are acceptable, and will not adversely affect the system unless they reach the point to where they begin to restrict the fuel flow. If contaminants and water are collected in the separator strainer continuously and frequent cleanings are necessary, it may be necessary to have the fuel tank drained, as a large amount of contaminated fuel may have been introduced into the system.

The filtering element of the fuel/water separator requires replacement every 10,000 miles or 12 months, whichever comes first. Problems with contaminated fuel may constitute an earlier replacement, as a large amount of contaminants may clog the filter.

If poor performance of the vehicle is noted, along with the necessity of frequent strainer cleaning, the separator filter probably requires replacement.

The final fuel filter (Caterpillar fuel filter) requires replacement at the oil change interval. Again, problems with contaminated fuel may necessitate earlier replacement.

When replacing fuel filters, never fill the filter with diesel fuel before installing it onto the filter base. This fuel is not filtered, and any contaminants that may be present will go directly into the engine that may cause problems with the delicate fuel injection components.

GAUGES AND INDICATOR LIGHTS

The gauges and indicator lights on your vehicle enable the operator to monitor the chassis systems in order to be aware of any possible problems with the systems. Always monitor the gauges and indicator lights during engine start-up and while operating the vehicle, as they are usually the first indication of a problem with the components they monitor. A good habit to develop is to glance at the gauges every few minutes that you are operating the vehicle, and be aware of any significant changes in the information they provide.

On vehicles equipped with in-dash electronic monitors, it is normal for readings to vary between the dash gauges and the electronic read-out. This is due to differing sensitivities of the sensors and sensor placement. While the readings may vary (5% difference is normal), it is helpful to use both instruments in order to compare readings and possibly notice a discrepancy in one of the systems. Keep in mind that the monitor and the gauges use entirely separate systems for obtaining the information that they display.

Gauges

Listed below are gauge descriptions, “normal” readings which may be expected from the gauges, as well as maximum and/or minimum readings where applicable. Depending on the model of your vehicle, it may or may not have all of the listed gauges. Lower or higher readings than normal may occur on occasion when the vehicle is subjected to severe or abnormal conditions, and should be taken into account when operating the vehicle in extreme conditions.

Never allow the vehicle to operate when the vehicle exceeds the minimum and/or maximum allowable readings, as damage to the vehicle may result.

Engine oil pressure- Normal oil pressure for the engine is 35 to 70 psi with the engine running at rated speed. Minimum pressure for the engine is 5 psi. Do not allow the engine to operate at pressures less than 5 psi. Oil pressures will be exceptionally higher while the engine is cold, and will be lower than the 35 to 70 psi range when the engine is idling with hot oil.

If the oil pressure is suspected of being lower than 5 psi, or low pressure warning lights are activated, safely pull the vehicle to the side of the road and investigate the cause.

Water temperature (engine coolant)- Normal temperature is between 190 and 215 degrees f. The maximum water temperature allowed for continuous operation is 225 degrees f. When this temperature is reached a “High Coolant Temperature Warning” will be registered on the engine electronics. This condition will cause the “CHECK ENGINE” light to illuminate, and the engine electronics will begin limiting power for the vehicle (“de-rating power”). If this occurs, reduce the load on the engine by slowing the vehicle and manually shifting the transmission to a lower gear to increase the engine rpm. If the water temperature continues to increase, safely pull the vehicle to the side of the road and allow the engine to cool. Water temperature of 230 degrees f and above will be an “overheat” condition. Do not attempt to operate the vehicle with a temperature of 230 degrees f or higher, as engine damage may result.

Transmission temperature- Normal temperatures for the transmission is between 140 and 200 degrees F. The maximum allowable temperature for the transmission fluid is 250 degrees F, at which point the transmission electronics will inhibit operation in order to help prevent damage. Never operate the vehicle when the transmission temperature exceeds 250 degrees F.

Volts- Normal voltage for the vehicle is between 12.5 and 14 volts, and greatly depends on the amount of electrical draw being used to recharge the batteries and the draw from electrical components being used. Have the system checked if voltages below 12 or above 15 volts are noted with the batteries are charged and all electrical components are turned off. Continued operation of the vehicle with low voltage from the charging system may result in the engine shutting down, as the electronics require a certain amount of voltage to operate the engine. Excessive voltage can cause the batteries to overcharge, resulting in premature failure.

Fuel gauge- The fuel gauge displays the approximate amount of fuel in the fuel tank. When checking the fuel level, the ignition must be in the “ON” position, and the vehicle must be on smooth, level ground. It is normal for the fuel gauge needle to move slightly while operating the vehicle due to fuel movement in the tank.

Tachometer- The tachometer indicates the approximate number of engine revolutions per minute (rpm). Normal reading is between 700 and 2340 rpm. Maximum reading under any situation is 2900. Use the tachometer while driving to help prevent the engine from lugging or over speeding. Engine over speed occurs when the engine runs faster than it is designed for, and may result in damage if it is allowed to do so. While both the engine and transmission electronics monitor engine speed and take action to prevent it from happening, it is wise to monitor the tachometer for this condition, especially when operating the engine brake.

Speedometer and odometer- The speedometer indicates the speed of the vehicle in miles per hour or kilometers per hour. The odometer records the total distance the vehicle has traveled.

Turbo boost gauge - The turbo boost pressure is the air pressure developed by the turbocharger on the engine. Normal readings for the turbo boost gauge varies between 0 and 28 psi, depending on engine load, ambient temperature, barometric conditions, as well as other factors.

Many factors affecting the boost pressure are a result of the interpretation of the gauge readings. Interpreting the gauge and boost will be gained with experience. As you operate the vehicle, you will learn what readings are normal for certain conditions. A sudden loss of engine power accompanied by a drop in the turbo boost pressure is the result of a problem with the charge air system, and should be investigated as soon as possible. Lower than normal pressures over an extended time may be the result of air cleaner restriction, and can be corrected by replacing the filter element.

Indicator Lights

Check engine light- The “CHECK ENGINE” or “ENGINE WARNING” indicator light activates both during engine start-up, as well as when the engine electronics determine a possible problem with those engine systems which it monitors. For more information regarding this indicator light, please see the section titled “ENGINE” in this manual, or refer to the Caterpillar Operation & Maintenance Manual.

Brake service- The “BRAKE SERVICE” indicator light activates when a potential problem with the service brakes of the vehicle is detected. Always seek service assistance as soon as possible if this light activates, especially if there is an evident problem with the brake system that can be noticed by the operator. Never operate the vehicle when the brakes are not functioning.

Anti-lock brake (ABS)- The “ABS” indicator light activates during engine start-up and when a potential problem is detected with the Anti-Lock Brake System. The indicator light should illuminate momentarily during engine start-up to indicate that the system is working properly and then extinguish. If the indicator light fails to illuminate during engine start-up, or remains illuminated during vehicle operation, seek service as soon as is convenient to have the problem corrected. If a problem does occur with the ABS System causing the indicator light to remain lit, *normal* non-ABS braking will still be available for vehicle operation.

NOTE: The ABS switch is for service technician use only and does not activate or deactivate the system. It is used to recover diagnostic codes.

Park brake- The “PARK BRAKE” indicator light illuminates when the park brake is engaged. Never operate the vehicle when the park brake is engaged, as severe damage to the vehicle may occur, and the effectiveness of the brake will be diminished.

Do not shift OR Check trans- The “DO NOT SHIFT” or “CHECK TRANS” indicator light activates both during engine start-up, as well as when the transmission electronics determine that a possible problem has been detected with the monitored transmission functions.

For more information regarding this indicator light, please see the section titled “TRANSMISSION” in this manual, or refer to the Allison World Transmission Operator’s Manual.

SERVICE AND PARK BRAKE SYSTEMS

ABS Brake Systems

HYDRAULIC-OVER-HYDRAULIC

This system consists of a hydraulic power-booster and master cylinder unit mounted below the driver's side cab floor.

This unit uses hydraulic pressure from the chassis hydraulic system to provide power assist in the application of the brakes under normal conditions. In the event of a loss of chassis hydraulic pressure, a reserve electric pump will engage when operating the brake to provide power assist for the brake system.

The reserve pump can be tested by stepping on the brake pedal while the engine is not running. You should be able to hear the pump, as well as an alarm sounding and dash light warning while depressing the brake pedal. If this ever occurs while the engine is running, it may indicate a main hydraulic system malfunction, and you should seek service immediately.

PARK BRAKE

The park brake utilizes a spring chamber to apply the driveline-mounted disc park brake. When no hydraulic pressure is applied to the spring chamber, (park brake control in the "ON" position, or inadequate hydraulic pressure in the system), the spring in the chamber applies force to the park brake cam, which engages the park brake caliper. When the park brake control is moved to the "OFF" position, pressure is supplied to the spring chamber, which overcomes the pressure of the spring. This operates the park brake cam and releases the park brake.

BRAKE SYSTEM MAINTENANCE

Lubrication, inspection, and fluid level checks comprise the maintenance requirements for this system. Check the brake fluid level daily, ensuring that the level of the fluid is within 1/8" from the top of the reservoir. It is normal for the level to gradually lower as the brake pads wear, but a sudden drop in the fluid level may indicate a brake leak or other malfunction with the brake system. Every 12 months or 10,000 miles, have the brake system inspected for brake pad wear, leaks, rotor condition, and any unusual or extreme condition. The rear brake caliper slides should also be lubricated at this time to ensure proper operation of the brake calipers. Inadequate lubrication can result in slow release of the brake pads from the rotors and cause premature wear of the brakes, excessive brake noise, and overheating of the brakes.

The park brake requires an inspection every 18 months or 15,000 miles for loose components and worn parts. A function check of the park brake should also be performed to ensure that it is working properly.

EXHAUST SYSTEM

The exhaust system of your vehicle consists of exhaust piping and a muffler to safely and cleanly transfer exhaust gases from the engine to the atmosphere. Visually inspect the exhaust system for damage and leaks. Look for large dents, holes, excessive corrosion, and looseness of components. The presence of black soot on the exterior of the tubing may indicate an exhaust leak and should be further investigated. Have the system evaluated by a professional if any of these conditions exist.

AIR INTAKE AND CHARGE AIR SYSTEM

The air intake and charge air system supply the engine with clean air in order for proper combustion and performance. Air enters the system and is cleaned through the use of the air filter assembly. The air then passes through the engine turbocharger, which pressurizes the air. This pressurized air then passes through the charge air cooler (inter cooler) mounted to the exterior of the radiator assembly, where the air is cooled before entering the engine intake manifold.

It is critical to ensure that the air entering the engine is as clean as possible, as contaminated air can cause destruction of major engine components if allowed to continue. Even small amounts of contaminants can do irreparable harm to the engine. Inspect the air intake system on a weekly basis, looking for damage, loose connections, and wear to the air ducting, clamps, and filter housing. Check to ensure that the ducting is not rubbing or wearing on other components and that all components are securely in place. Have any problems investigated and corrected as soon as possible in order to prevent engine damage.

Located on the chassis service center is an air restriction indicator that relays the amount of restriction present in the air intake system and requires inspection daily. If the yellow indicator approaches the red (top) area of the air restriction indicator, it is signaling that the air filter is beginning to become excessively dirty. Have the air cleaner element serviced if excessive restriction of the intake system is indicated. The filter element should also be replaced every 12 months or 10,000 miles regardless of the position of the air restriction indicator to ensure proper cleaning of the intake air.

When operating the vehicle in extremely dusty or dirty environments, check the air restriction indicator more frequently. Operation in these conditions may necessitate more frequent air filter change intervals.

ELECTRICAL SYSTEM

The chassis electrical system utilizes two 12 volt batteries connected in parallel to provide electrical power for chassis components. The chassis batteries are charged using the belt-driven alternator on the engine, which also charges the “house” batteries. The two sets of batteries use a battery isolator in order to separate the two different circuits, which allows the batteries to charge from the same source and yet remain on separate circuits. Mounted to the inside wall of the bed box frame is the “isolator panel”, on which the battery isolator, as well as other electrical components are mounted.

Circuit protection for the electrical system is provided through the use of fuses and automatic reset circuit breakers. Located on the isolator panel with the other components, are several high amperage fuses, which serve to protect both the chassis and house 12 volt main power supplies in the event of a problem. An in-line fuse located at the alternator provides circuit protection for the alternator exciter wire. A fuse block mounted to the battery tray framework contains all other fuses for the chassis systems including the engine and transmission electronics. An identification diagram for these fuses can be found in Appendix I of this manual.

Maintenance of the chassis electrical system includes battery care and inspection of electrical connections. Batteries should be cleaned and inspected on a weekly basis in order to avoid potential problems. Clean any dirt or other contaminants from the batteries and inspect the battery terminals for any signs of corrosion. Check the battery cable ends for looseness and damage. Clean, repair, or replace any components which show signs of corrosion or other damage. After servicing the batteries, protect the terminals and connections with battery terminal protectant to help prevent corrosion.

Electrical connections for the chassis should be inspected each time the engine oil and filter is serviced. Inspect for loose or broken connections, corrosion, or other problems that may interrupt the electrical circuit. Major ground connections that should be inspected include the ground stud on the passenger side of the engine block and the engine-to-frame ground at the starter. Other electrical connections that should be inspected include alternator terminals, isolator panel connections, and starter connections.

TIRES AND WHEELS

Your vehicle's tires and wheels have been matched to your vehicle in order to provide a balance between ride comfort, long tire wear, and handling performance. The balance between performance characteristics is related to the vehicle operation, the condition and maintenance of the tires and wheels, as well as the condition of the steering and suspension systems. Hard driving practices, (rapid acceleration, heavy cornering, and unnecessary heavy braking), failure to maintain proper alignment settings, and incorrect tire pressures can all have a detrimental effect on tire wear.

Tire pressures should be checked on a daily basis to ensure proper inflation pressures. Recommended tire inflation pressures can be found in Appendix E of this manual, this also contains information on how to calculate the recommended pressure for your vehicle. Maximum cold tire pressures are noted on the side wall of the tire and should never be exceeded. Always check the tire pressure when the tires are "cold"; checking hot tires will give erroneous tire pressure.

Tires should also be inspected daily for any foreign objects embedded in the tread or sidewall, unusual tire wear, or any other damage to the tire or wheel. Have the tire examined by a professional if any unusual conditions exist.

In order to maintain an even wear life of all the tires, they should be rotated every 12 months or 10,000 miles. Front and rear tires will exhibit differing wear patterns, as they perform different functions as the vehicle is being operated. Tire rotation will help prevent uneven wear of the tires and will maximize the life of the tires. It is recommended that tires be rotated in the following manner:

1. Place the rear inner tire on the front axle
2. Move the rear outer dual tire to the inner dual position
3. Place the front tires in the outer dual position

It is strongly recommended that only trained professionals with the proper tools and equipment remove, install, or replace tires and wheels, as special training and tools are required when performing these tasks. It is important to maintain the proper torque specification of 450 ft-lbs. in order to ensure correct wheel installation. Any time that the lug nuts have been removed and re-installed, the torque should be rechecked after 500 miles of operation. The torque of the lug nuts should also be checked on at a regular interval of 5,000 miles or every 6 months.

SECTION 3 SERVICING GUIDELINES

Every effort has been made to make this section as complete as possible with regard to the recommended service requirements for your chassis. Information for all components including the engine and transmission are included in order to help prevent the need to refer to several different publications for chassis service information. We do encourage you, however, to read and understand all of the publications for your chassis components, as it is not possible to expound in detail on all of the available information for these components. In particular, more detailed information regarding the maintenance requirements and instructions for the engine and transmission should be read and understood.

Most recommended maintenance intervals listed in this publication have both a mileage, as well as a calendar time interval for maintenance. Always use the maintenance interval that occurs first when planning maintenance.

As you browse through the Caterpillar Operation & Maintenance Manual for your engine, you will see a section labeled “Optimized Oil Change Intervals”. We encourage you to study this section closely, as it may provide you an option to extend the oil change intervals for the engine, depending on your fuel consumption and other factors. Prior to adopting this method for oil change intervals, please contact your local Caterpillar dealer for more information.

For ease of use, two separate charts are used for displaying the maintenance intervals. Daily and weekly intervals use one type of chart, and all other intervals are displayed on a different chart.

M

RECOMMENDED MAINTENANCE INTERVALS

SERVICE CODES

R-Replace A-Adjust CL-Clean D-Drain L-Lubricate C-Check

I-Inspect; replace, repair, or service as needed

Daily

MAINTENANCE DESCRIPTION	CODE	PAGE
Daily inspection-leaks, hose and belt condition, trash build-up	I	3-3
Engine oil level	I	3-4
Engine coolant level	I	3-4
Air restriction indicator	C	3-4
Tire pressure; tire condition	I	3-4
Brake fluid level	I	3-4
Fuel/water separator	I / D	3-4
Hydraulic fluid level	I	3-5
Transmission fluid level	I	3-5

Weekly

MAINTENANCE DESCRIPTION	CODE	PAGE
Front axle lubrication level	I	3-6
Batteries	I / CL	3-7

Scheduled Maintenance

R-Replace A-Adjust CL-Clean D-Drain L-Lubricate C-Check I-Inspect; replace, repair, or service as needed

Maintenance Description	Page	Every 3 mo. 2500 ¹	Every 6 mo. 5000 ¹	Every 12 mo. 10000 ¹	Every 18 mo. 15000 ¹	Every 24 mo. 20000 ¹
Rear axle lubricant level	3-8	I				
Lube steering, front axle, driveline	3-9		L			
Torque wheel lug nuts	3-9		C			
Rear axle lubricant	3-9			R		
Fuel/water separator	3-9			R		
Brake system	3-10			I,L		
Air filter element	3-10			R		
Rotate tires	3-11			R		
Transmission filter and fluid	3-11		R ²		R	
Hydraulic system	3-11				R,I	
Park brake	3-11				I	
Engine valve lash	3-12			C,A		
Engine oil and filter	3-12			R		
SOS oil analysis (rcmd)	3-12			Test		
Engine cooling system	3-12			I		I,CL,R
Engine crankcase breather	3-13			CL		
Engine accessory drive belts	3-14			I		
Engine hoses and clamps	3-14			I		
Electrical connections	3-14			I		
Engine exhaust system	3-14			I		
Final fuel filter	3-14			R		
Fan drive bearing	3-15			L,I		
Engine	3-15					CL
Component inspection	3-15					I,C

MAINTENANCE INSTRUCTIONS

Daily Maintenance Descriptions

DAILY INSPECTION- Perform an inspection of the chassis prior to operating the vehicle. Look for items such as worn or frayed fan belts, fluid leaks, disconnected or loose hoses, missing clamps, and loose wiring. Catching a problem before your trip can save time, frustration, and expense, as well as a potential break-down.

¹ Whichever occurs first

² Initial filter and fluid change interval for the transmission is within the first 5,000 miles; subsequent service is 18 months or 25,000 miles, whichever occurs first.

ENGINE OIL LEVEL- With the vehicle parked on level ground and the engine stopped, locate the engine oil dipstick at the rear of the vehicle. Remove the dipstick from the engine and wipe it clean with a clean cloth. Fully insert the dipstick back into the tube until it bottoms; remove the dipstick again and note the oil line formed on the dipstick. Maintain the oil level between the add and full marks on the dipstick. Never operate the vehicle with the oil level either above the full line, or below the add line of the dipstick. Add or drain oil for the engine until it is between the add and full lines.

ENGINE COOLANT LEVEL- The engine coolant level is checked at the steel surge tank, which is mounted above the radiator. The coolant level should be maintained so that the level is within the sight glass when the engine is “cold”, or when the cap is removed after the engine has cooled. If it is necessary to add coolant, always use the proper mix of coolant and water. Straight water or straight coolant can affect the mixture present in the cooling system.

WARNING

Never remove the coolant cap when the engine coolant is hot; let the system cool prior to removing the cap.

AIR RESTRICTION INDICATOR- Check the air restriction indicator located on the chassis service center for the amount of restriction present in the air intake system. If the yellow indicator is approaching the top of the gauge, it is indicating high restriction in the intake system, and the air filter should be serviced as soon as possible.

TIRE PRESSURE; TIRE CONDITION- Check the tire pressure with a tire gauge on a daily basis to ensure proper inflation pressures. Appendix E in this manual will help you in determining the proper inflation pressure for the tires. Always check the tire pressure when the tires are “cold”, as “hot” checks will give erroneous pressures. While checking the tire pressures, also inspect the tires for damage, embedded foreign objects, bent or cracked wheel rims, and other unusual conditions. Have the tire evaluated by a professional if any unusual conditions exist.

BRAKE FLUID LEVEL- Inspect the level of the brake fluid reservoir located at the front of the vehicle. The level should be maintained within 1/8” of the top of the reservoir. When adding fluid, always clean the cap and top of the reservoir before removing the cap in order to prevent contamination from entering the reservoir. It is normal for the fluid level to gradually drop, however any sudden decrease in the level of the fluid could result from a leak in the system and should be investigated immediately.

FUEL/WATER SEPARATOR- Inspect the fuel/water separator for excessive amounts of water, and the clear pre-filter or filter bowl for excessive contamination that approaches the top of the pre-filter or bowl. While small amounts of contamination are acceptable, drain and/or clean the pre-filter or separator if excessive amounts exist.

For manual priming fuel water separators:

If excessive amounts of contamination are found by visual examination of the filter bowl, it will be necessary to remove those contaminants from the system. With an appropriate container beneath the drain, open the drain and operate the pump. Contaminates will be pumped out of the drain. Close the drain.

For electronic priming fuel/water separators:

Excessive amounts of water in the system will be signaled by the red "H2O" light located in the control panel at the service center. If the light is illuminated, it will be necessary to activate the "H2O PURGE" function of the separator in order to purge the water from the system. With a suitable container in place beneath the discharge tube of the separator (located at the rear of the separator), press and release the "H2O PURGE" button. The water will be pumped directly into the container, and the pump will stop after approximately 20 seconds. If the red "H2O" light is still illuminated after the purge cycle is complete, repeat the process. Properly dispose of the water/fuel mixture that was purged.

To clean the pre-filter, remove the thumb bolt, washers and top block from the assembly. Remove the pre-filter and O-rings from the assembly and clean by partially filling with diesel fuel and shaking vigorously to dislodge the contaminants. Repeat until the pre-filter is clean. Before reinstalling, inspect the O-rings for damage or hardness. Replace the O-rings if either of the conditions exist. . Before reinstalling, inspect the O-rings for damage or hardness. Replace the O-rings if either of the conditions exist. Ensure the O-rings are in place at each end of the pre-filter. Install the pre-filter into the separator assembly with the arrow on the pre-filter pointing down. Replace the top block over the pre-filter and install the "thumb bolt" and washer until the thumb bolt is hand tight. Using pliers, tighten the thumb bolt an additional 3/4 turn. Over or under tightening may damage the housing and/or result in a leak. Activate the "AIR PURGE" on the control panel. Immediately start and operate the vehicle at high idle for 3 minutes to insure that any air in the system is evacuated.

HYDRAULIC FLUID LEVEL- With the engine stopped, check the hydraulic fluid level in the plastic reservoir located in the service center. The level should be between the "Min" and "Max" level labeled on the reservoir. Use Dexron II or Dexron III fluid.

WARNING

Do not remove the cap from the reservoir with the engine running, as fluid may be expelled from the reservoir.

TRANSMISSION FLUID LEVEL- It is recommended that the transmission fluid level be checked using the oil level sensor in the transmission. This allows the level to be checked electronically, as this is the most accurate method. When checking the transmission fluid, it is most easily accomplished at the end of the day, as the transmission will be sufficiently warm to obtain a correct reading. The transmission must be over 140 degrees to obtain an accurate reading.

M

To check the level electronically, park the vehicle on level ground with the transmission in neutral, park brake on, engine running at low idle, and the transmission temperature above 142 degrees. Simultaneously press both the UP↑ and DOWN↓ arrows on the pushbutton shift selector. The display on the shifter may “count down”, allowing for the transmission fluid to settle prior to a reading being made. When the electronics are ready to take a reading, “O” “L” will be displayed on the shifter followed by either “L” “O”, “H” “I”, or “O” “K”. “L” “O” designates that the fluid level is low, “H” “I” designates that the fluid level is too high, and “O” “K” designates that the level is acceptable. A “L” “O” or “H” “I” designation will be followed by a numerical value such as “2”, which represents the amount in quarts that the transmission level is low or high.

If “O” “L” is displayed followed by “--” and a two digit number, there is a problem associated with the system, which may be a system malfunction, or a condition for proper fluid level information has not been met. If this occurs, reference the Allison Operator’s Manual for more information and a description of the two digit fault code that was indicated.

When checking the transmission manually with the transmission dipstick, use the following guidelines to determine the proper levels:

With the transmission “cold” and the engine off, the level should be at or near the “Full hot” mark. Use this procedure after servicing the transmission to ensure that enough fluid is in the transmission for safe operation until a “hot check” can be performed. With the transmission “cold”, engine running, and transmission in neutral, the level should be between the “cold add” and “cold full” marks. With the transmission “hot”, engine running, and transmission in neutral, the level should be between the “hot full” and “hot add” marks.

When checking the transmission level manually, it may be necessary to check it several times in order to obtain a consistent reading. Again, the electronic check is the more accurate method of checking the transmission level, as the electronics takes into account the specific temperature of the transmission when obtaining the level.

Always maintain the transmission fluid level at the proper operating level, as low or high fluid levels can result in poor performance or damage to the transmission.

Weekly Maintenance Descriptions

FRONT AXLE LUBRICATION LEVEL- Inspect the level of the front axle hub lubricant in order to ensure that it is at the proper level. The level should be maintained so that it is between the “MINIMUM OIL LEVEL” and the center fill plug on the hub, as shown in diagram A.

The hub has both a fill plug (rubber plug in the center of the hub), as well as a drain plug mounted to the side of the hub. To add lubricant, pry the center plug from the hub and add lubricant. When finished, push the plug firmly into place, ensuring that it is evenly seated.

If it is necessary to drain fluid from the hub, position the tire so that the drain plug is at the bottom. Remove the stainless steel hub cap from the center of the wheel rim and remove the plug using an Allen wrench in the hole provided. When re-installing the plug, ensure that the O-ring seal is in place, and tighten the plug to 25 in-lbs.

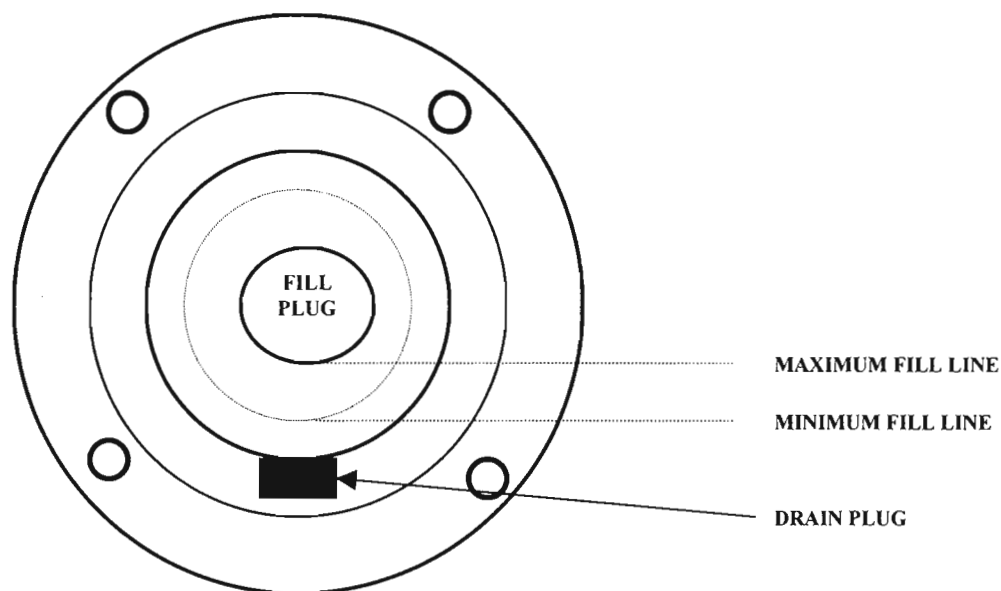

DIAGRAM A- FRONT AXLE HUB COMPONENTS AND FILL LEVELS

WARNING

Batteries contain sulfuric acid and can cause chemical burns. Avoid contact with skin and eyes to prevent injury.

Always wear protective glasses and gloves when working with batteries. Wash hands after touching batteries and connections.

Batteries produce flammable gases that can explode. Keep open flame, sparks, and other sources of ignition away from the batteries.

BATTERIES- Inspect and clean the batteries on a weekly basis to help prevent problems from corrosion and loose connections. Inspect the batteries for signs of leaks, corrosion on the terminals and damaged cable ends. Clean, repair, or replace any components which show signs of corrosion or other damage.

Check the level of the electrolyte in the batteries by removing the caps on the top of the batteries. The electrolyte level should be within 1" of the bottom of the inner plastic "sleeve" (vent well) of the hole. Never allow the electrolyte level to fall below the top of the battery plates. If the level is low, add distilled water until the level is to the bottom of the plastic sleeve.

M

Frequent battery use combined with hot weather can deplete the electrolyte level rapidly, so more frequent checks in these conditions may be necessary.

The most important factor in ensuring long battery life is the condition of the batteries charge. For optimum battery life, the battery charge should be kept at 100% at all times. Allowing the batteries to discharge fully and then recharging (deep cycling), long periods in a discharged state, as well as overcharging, will take their toll on the batteries life expectancy. Always attempt to keep the batteries fully charged, especially when the vehicle is being stored.

Scheduled Maintenance Descriptions

REAR AXLE LUBRICANT LEVEL-3 months/2,500 miles-

WARNING

Always check the rear axle lubricant level when the axle is cool, as temperatures of 190 degrees can be reached form operation and can cause severe burns.

Clean the area around the fill plug, which is located approximately halfway up the axle housing (see Diagram B). Remove the fill plug and observe the lubricant level. The level must be maintained even with the bottom of the fill plug for proper lubrication. Correct the level as necessary. Re-install the fill plug and tighten to 35-50 ft-lbs.

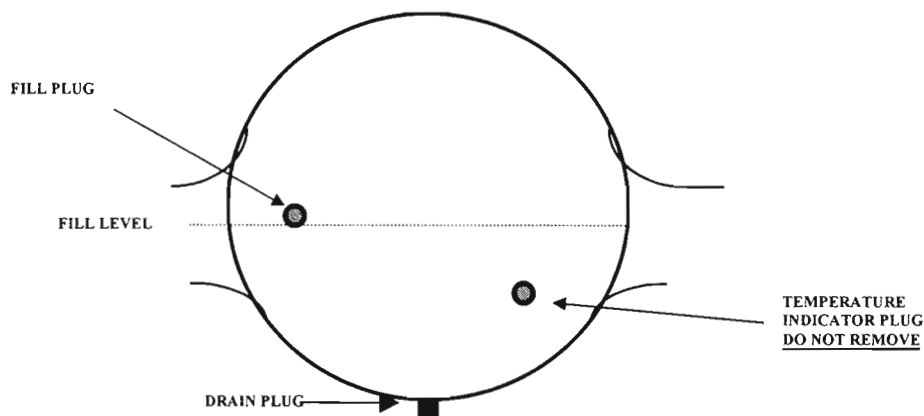

DIAGRAM B- REAR AXLE PLUG LOCATIONS

Some models may be equipped with a temperature indicator plug-Do not remove if present.

REAR AXLE LUBRICANT- Replace the rear axle lubricant (initial change at 1,000 miles, subsequent change at 12 months or 100,000 miles, whichever comes first). See Diagram B for component location. Do not attempt to drain lubricant when axle is hot, as it can produce serious burns! With vehicle parked on a level surface and rear axle warm, place a large container under axle. Remove drain plug and allow axle to drain completely. Dispose of oil properly.

Clean the drain plug and test or replace plug (see section “Rear Drive Axle” in this manual). Install and tighten drain plug to 35-50 ft-lbs. Clean the area around the fill plug from the axle housing bowl. Fill the axle with approved lubricant until the level is even with the bottom of the fill plug hole. Install and tighten the fill plug to 35-50 ft-lbs.

LUBRICATE STEERING, FRONT AXLE, DRIVELINE-6 months/5,000 miles-Lubricate all zerk fittings on the front axle, steering linkage, and drive-line. Fitting locations can be found in Appendix A, “Lubrication Charts”. Lubricate steering and axle zerks until fresh grease can be seen slightly extruding from the joints. Drive-line u-joints should also be lubricated until fresh grease can be seen extruding from the u-joint caps. The drive-line slip shaft should be lubricated until grease is seen extruding from the relief hole at the spline end of the slip yoke. When grease appears, cover the hole with a finger and continue lubricating until grease slightly extrudes from the slip yoke seal.

TORQUE WHEEL LUG NUTS-6 months/5,000 miles-Have all wheel lug nuts torqued to 450 ft-lbs. in order to ensure proper torque. This procedure should only be done by a qualified technician. It also should be done after 500 miles of operation any time that the wheels have been removed.

FUEL/WATER SEPARATOR-12 months/10,000 miles- Replace the spin-on filter element.

For manual priming fuel/water separators:

1. Loosen the drain valve and vent plug to drain the filter into an appropriate container.
2. Remove the filter and bowl by turning counter-clockwise. Remove the bowl from the filter element.
3. Clean the O-ring seat and apply clean fuel or motor oil to the seals.
4. Spin the bowl onto the new filter element. Install the element and bowl onto the filter head and tighten snugly by hand. Do not tighten with tools.
5. With the vent plug loosened, and the drain valve tight, operate the priming pump until fuel purges from the vent. Tighten the vent plug.
6. Operate the priming pump again until it becomes difficult to operate. Start the engine and operate at high idle until it runs smoothly.

For electronic priming fuel/water separators:

Disconnect the water sensor wiring connector at the bottom of the filter and remove the cap from the Shrader valve. With a suitable container in place beneath the filter, disconnect the discharge line from the bottom of the filter and open the Shrader valve to allow the filter to drain. Remove the spin-on filter from the filter head and properly dispose of the filter and drained fuel. Coat the seal of the new filter with clean fuel and spin the element into the head by hand until it is seated firmly.

To fill the filter with fuel and purge out the air from the system, activate the "AIR PURGE" by pressing and releasing the "AIR PURGE" switch on the control panel. Depress and hold the Shrader valve on the filter assembly to release excess air from the system until fuel begins to flow from the valve. Release the valve when fuel flows from it. After the pump operation ceases (approximately 50-60 seconds after activating), restart the "AIR PURGE" cycle and start the engine approximately halfway through the cycle. Run the engine at high idle for 3 minutes in order to help purge any remaining air from the system. The engine may run rough for a few minutes as air is forced through the system. If the engine stalls after starting, re-bleed the system by following the instructions again.

BRAKE SYSTEM-12 months/10,000 miles- Have the brake system inspected for brake pad wear, leaks, rotor condition, and any unusual or extreme condition. The rear brake caliper slides should also be lubricated with a silicone grease lubricant to ensure proper operation of the brake calipers.

To lubricate the brake caliper slides, jack the vehicle and support it on jack stands. Remove the wheels and tires from the vehicle to gain access to the brake calipers. Using a 1/2" wrench, remove the retainer bolt from the brake support and remove the retainer from between the brake support and caliper. Using care not to damage or stretch the brake line, remove the brake caliper from the assembly and support it so that it will not fall (never allow the caliper to hang from the brake line, as it may be damaged). Clean any old lubricant or rust from the slide surfaces of the caliper and brake support using a wire brush and brake cleaner.

Apply new lubricant to the slide surfaces of the brake caliper, and re-install the caliper onto the brake support, ensuring that the caliper is mounted securely under the spring assembly. Re-insert the retainer between the caliper and brake support, ensuring that it is positioned properly. At this point, attempt to remove the caliper from the assembly to double-check correct caliper mounting. Apply Loctite #81789 (blue) to the retainer bolt threads, and install. Torque the retainer bolt to 12 -20 ft-lbs and re-install the tires.

AIR FILTER ELEMENT-12 months/10,000 miles- Replace the air filter element at the recommended service interval or when restriction, as indicated by the air restriction indicator is excessive. To replace the filter element, loosen and remove the clamps holding the air inlet and outlet hoses to the filter. Remove the hoses to the filter and inspect the hoses and clamps for any damage; replace or correct as necessary. Unfasten the two clamps holding the filter assembly to the bracket and remove the filter assembly.

Place the new filter in the clamps and secure it in place. Re-install the inlet and outlet hoses and clamps. Inspect the assembly to ensure a tight seal is made with the hose clamps.

ROTATE TIRES-12 months/10,000 miles-Rotate the tires in order to prevent uneven tire wear and to maximize the tread life of the tires. Rotate the tires in accordance with the diagram in Diagram C.

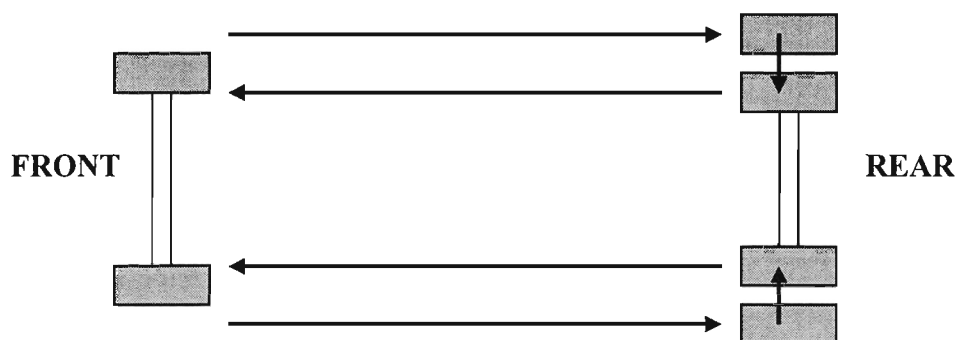

DIAGRAM C- TIRE ROTATION

WARNING

It is recommended that only trained personnel service the air dryer, as the air dryer contains air under pressure, and improper procedures could result in serious injury.

TRANSMISSION FILTER AND FLUID- Initial change at 5,000 miles; every 25,000 miles or 18 months thereafter. Replace the transmission fluid and filters. Due to the complexities of the Allison World transmission, it is recommended that only trained professionals perform this service of the transmission.

If the operator wishes to replace these components, we recommend obtaining Allison publication SA2159B, Mechanic's Tips, for detailed information on servicing the transmission.

HYDRAULIC SYSTEM-18 months/15,000 miles-Replace the hydraulic fluid for the hydraulic system, and perform an inspection of the hydraulic system, paying close attention for abraded hydraulic lines and leaks. To replace the fluid, siphon or pump the fluid into a suitable container until it is empty. Fill the reservoir with approved fluid to the "Max Line" on the reservoir. Start the engine and allow the vehicle to idle for 3-5 seconds. Turn the engine off, and re-fill the reservoir to the "Max" line. Re-start the engine and allow it to idle for 10 minutes while intermittently operating the steering to allow any air in the system to be purged. Re-check the fluid level. Dispose of the drained fluid in an appropriate manner.

PARK BRAKE- 18 months/15,000 miles- Inspect the "park" brake system for loose components, worn parts and loose fasteners.

M

ENGINE VALVE LASH - Initial check and adjustment at 50,000 miles or 12 months, and again at 24 months or 100,000 miles. Have the engine valve lash checked and adjusted according to the information in the Service Manual. By ensuring proper adjustment, certain problems can be alleviated. Problems such as reduced engine efficiency and/or shortened engine component life that can arise from improper adjustment.

ENGINE OIL AND FILTER- 12 months /10,000 miles- Replace the engine oil and filter. Refer to the Caterpillar Operation & Maintenance Manual if performing this procedure for the first time, also for special notices regarding this procedure.

WARNING

Use extreme caution when draining the oil. Hot oil can cause severe burns.

With the vehicle at normal operating temperature, park on a level surface and stop the engine. Remove the two crankcase drain plugs from both the deep and shallow portions of the oil pan to allow the oil to drain. Install the drain plugs back into the oil pan and tighten to 40-60 ft-lbs. Remove the oil filter.

NOTE: It is recommended that the used oil filter be opened and the element examined for excessive wear particles; see the Caterpillar Operation & Maintenance Manual for information on this procedure.

Wipe off the filter base surface and ensure that all old gasket is removed. Apply clean engine oil to the gasket of the new filter, and install the filter until the gasket contacts the filter base. Tighten the filter an additional 3/4 turn. Do not over-tighten. Remove the oil filler cap (located at the rear of the vehicle) and fill the crankcase with the amount of oil determined during the dipstick calibration. Allow time for the oil to drain into the sump and start the vehicle. Run the engine at low idle for three minutes while observing engine and filter for leaks. Stop the engine and allow the oil to settle for 5 minutes. Check the level of the engine oil with the dipstick. Correct the level as necessary.

SOS OIL ANALYSIS (RECOMMENDED)- 12 months /10,000 miles- Caterpillar recommends the use of a regularly scheduled lube analysis program to monitor engine wear and maintenance requirements of the engine. For assistance in establishing an oil analysis program for your engine, please contact your local Caterpillar dealer for complete information.

COOLANT SYSTEM-Inspect at 12 months/10,000 miles;
Inspect, clean, and replace at 24 months/20,000 miles.

12 months /10,000 miles- Inspect the cooling system for the proper amount of Supplemental Coolant Additive (SCA) in the system. Using the Caterpillar 8T5296 Test Kit, ensure that the coolant has a three to six percent concentration of SCA.

The test kit will measure the amount of SCA in the system and give recommendations for maintenance. Inspect the “Inter-cooler” and radiator fins for insects, dirt, and other debris. Clean or remove any blockage, using compressed air or high pressure water. If high pressure water is used, direct the stream in line with the fins to prevent damage. If necessary, non-caustic solvent may be used to disperse oil, grease, or grime. Examine fins and mounting brackets for any visible damage and correct as necessary.

24 months/20,000 miles- Inspect and clean the cooling system and charge air systems to promote system cleanliness and to enhance engine cooling. Please refer to the Caterpillar Operation & Maintenance Manual for detailed information regarding the 24 month /20,000 mile maintenance interval. This service includes draining the engine coolant, flushing/cleaning the cooling system, inspecting the water pump standpipe, replacing the thermostat, gasket and seal, and replacing the coolant.

Stop the engine and allow it to cool. Remove the cap from the surge tank and place a large container beneath the drain valve on the radiator. Open the “drain valve” and allow the cooling system to drain.

With the drain valve open, flush the cooling system with clean water to remove debris. Dispose of the old coolant mixture appropriately. Close the drain valve and fill the cooling system with a mixture of clean water and Caterpillar Fast Acting Cooling System Cleaner at a ratio of 1 pint cleaner to 4 gallons of water. Install the surge tank cap and run the engine for 30 minutes at operating temperature. Stop the engine and allow the system to cool. Loosen the surge tank cap and open the radiator drain valve to allow the system to drain. Flush the system with clean water until the draining water is clear. Allow to drain completely.

Replace the thermostat. Loosen the hose clamps and remove the hose assembly from the radiator to thermostat housing assembly. Remove the thermostat housing assembly from the cylinder head. Remove the thermostat and gasket from the housing, along with the seal in the housing. Install the new thermostat, seal and gasket into the housing. Re-install the thermostat housing and connect the hose assembly. Tighten the hose clamps.

Ensure that the drain valve for the radiator is closed. Fill the cooling system with the recommended coolant/water/coolant additive mixture. Start the engine with the surge tank cap removed and allow the coolant to warm and the thermostat to open. Add coolant mixture until the coolant level in the surge tank is between 1/3 and 2/3 full. Replace the surge tank cap. Allow the engine to warm to operating temperature while observing for coolant leaks. Stop the engine.

Inspect the radiator core and Inter-cooler for dirt and debris build-up. Wash any accumulations using high pressure water, being careful not to damage the fins from excessive pressure. Any grease or oil build-up should first be treated with a non-caustic degreaser to ensure a thorough cleaning.

ENGINE CRANKCASE BREATHER- 12 months/10,000 miles- The engine crankcase breather is located on the engine valve cover. To clean, first remove the hose clamp and hose from the breather assembly.

Remove the bolt holding the breather cover; remove the cover. Wash the breather element in clean non-flammable solvent and allow the breather to dry. Re-install the element, cover, and bolts. Re-install the hose and hose clamp on the breather assembly.

ENGINE ACCESSORY DRIVE BELT- 12 months /10,000 miles- Inspect the drive belt on the engine for proper tension, excessive wear, cracking, or other problems. Normal belt wear is often characterized by even wear on the belt and the pulley. Keep in mind that a damaged belt may have become so from a problem with a pulley. If a damaged belt is noted, inspect the belt pulleys for signs of chips, cracks, dents, and pulley alignment.

To replace the drive belt, stop the engine, remove the keys from the ignition, and place notification at both front and rear ignitions stating "Do not start". Insert a 1/2" breaker bar at the tension release lever point of the belt tensioner. Rotate the belt tensioner to produce slack in the belt; remove the old belt. Install the new belt on the pulleys, referencing the diagram in Appendix J, leaving the belt off on the belt tensioner idler. Ensure that the belt is properly installed on all pulleys. With the breaker bar, rotate the belt tensioner to install the belt on the belt tensioner idler. Check the belt installation once again, and then start the engine and observe the belt to ensure proper installation.

ENGINE HOSES AND CLAMPS- 12 months/10,000 miles- Inspect all hoses, clamps, and fittings for leaks due to cracking, softness, and loose clamps/fittings. Look for signs of fluid leaks, damaged end fittings, ballooning, chafed, kinked, or crushed hoses, and loose clamps and fittings. Correct any deficiencies found.

ELECTRICAL CONNECTIONS- 12 months /10,000 miles- Inspect the electrical connections for loose or broken connections, corrosion, or other problems which interrupt an electrical circuit. Major grounds that should be inspected include the ground stud on the passenger side of the engine block, and the engine-to-frame ground at the starter. Other electrical components that should be inspected include the alternator terminals, isolator panel connections, and starter connections.

ENGINE EXHAUST SYSTEM- 12 months/10,000 miles- Visually inspect the engine exhaust system for damage and leaks. Look for large dents, holes, excessive corrosion, and looseness of components. The presence of black soot on the exterior of the tubing maybe an indication of an exhaust leak and should be further investigated. Have the system evaluated by a professional if any of these conditions exist.

FINAL FUEL FILTER- 12 months/10,000 miles- Replace the final fuel filter. Loosen (do not remove) the bleed valve on the filter base in order to relieve any fuel system pressure and also to bleed the air from the system. Use a suitable container or cloth to catch any fuel which may drain from the fitting. Remove the old filter from the filter head and discard appropriately. Clean the filter mounting base and ensure that all of the old gasket is removed. Apply clean diesel fuel to the new filter gasket and install the filter until the gasket touches the filter base. Tighten the filter an additional 3/4 turn by hand. Do not over tighten.

For manual priming fuel/water separators:

1. With the vent plug loosened, and the drain valve tight, operate the priming pump until fuel purges from the vent. Tighten the vent plug.
2. Operate the priming pump again until it becomes difficult to operate. Start the engine and operate at high idle until it runs smoothly.

For electronic priming fuel/water separators:

With the bleed valve on the filter base loosened, activate the "AIR PURGE" switch on the fuel/water separator control panel.

Allow the system to cycle, and reactivate it until fuel begins to purge from the bleed valve. Close the bleed valve. After closing the bleed valve, allow the air purge to complete its cycle. Re-activate the air purge and allow it to run for 30 seconds, and start the engine. Run the engine at high idle for 3 minutes in order to help purge any remaining air from the system. Check the system for leaks. If the engine fails to start or stalls, follow the instructions for bleeding the fuel system in Appendix H.

FAN DRIVE BEARING-12 months/10,000 miles- Lubricate the fan drive bearing, using the grease zerk located at the top of the bearing between the fan pulley and engine block. Inspect the bearing by attempting to move the shaft in the bearing. It should be difficult to detect movement of the shaft. An inspection of the internal bearing components should be performed if excessive play is determined, which is best done by a Caterpillar service technician.

ENGINE- 24 months /20,000 miles- Steam clean any accumulated grease, oil, or other debris from the engine. Keeping the engine clean aids in the detection of leaks and will also improve the heat transfer characteristics of the engine.

COMPONENT INSPECTION- 24 months/20,000 miles- Inspect the following engine components to help prevent unexpected downtime and to reduce the chance of damage to other engine components.

Turbocharger- Inspect the turbocharger following the instructions outlined in the Caterpillar Operation and Maintenance Manual.

Crankshaft vibration damper- Inspect the vibration damper (visconic damper) located at the crankshaft belt pulley for dents, cracks, and fluid leaks. Replace the damper if any of these conditions exist.

Alternator- Inspect the alternator for loose/corroded terminals; correct as necessary. Check the alternator output with a voltmeter; the output should be between 12.5 and 14.5 volts.

Belt tensioner- Inspect the belt tensioner for excessive looseness, wobbling, and unusual noise. Correct as necessary.

Engine mounts- Inspect the engine mounts for deterioration and loose fasteners. Replace any mounts showing deterioration and tighten loose fasteners.

Starting motor- Inspect the starting motor for loose electrical connections. Operate the starting motor and listen for unusual or grinding noises when it engages. If unusual noises are heard, inspect the gear teeth for damage. Correct as necessary.

Water pump- Inspect the water pump for excessive leaking from the water pump seal. Small amounts of leakage are acceptable due to cooling and contraction of components. Replace the seal if excessive leakage is evident.

Water pump pulley bearing- Inspect the water pump pulley bearing for unusual noise, excessive looseness, and wobbling. Correct as necessary.

APPENDICES

APPENDIX A -- M-SERIES CHASSIS LUBRICATION POINTS

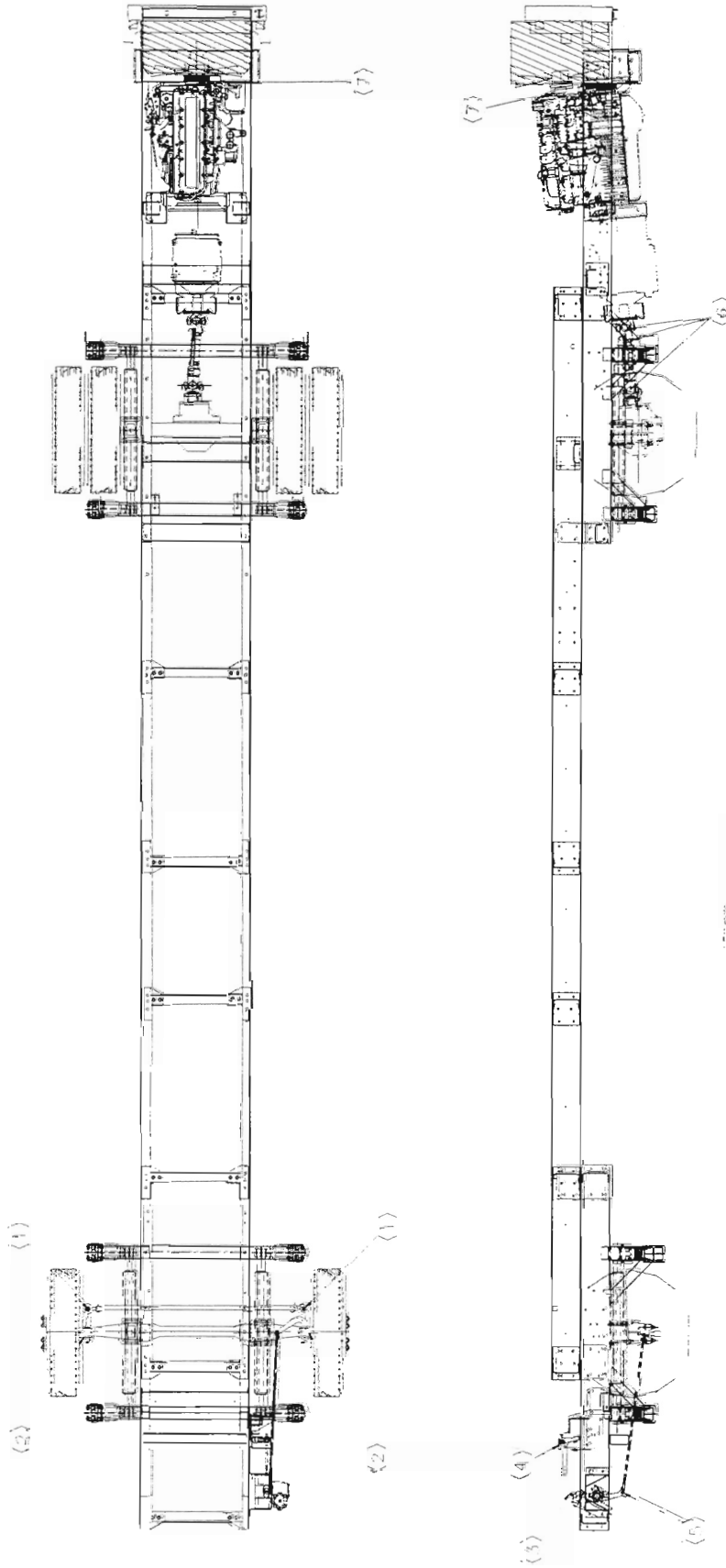

LEGEND

- (1) TIE ROD END (2 POINTS)
- (2) KING PIN - TOP & BOTTOM (4 POINTS)
- (3) STEERING ARM U-JOINTS (2 POINTS)
- (4) SWAY ARM (1 POINT)
- (5) STEERING DRUM (2 POINTS)
- (6) DRIVE LINE U-JOINTS & SLIP JOINT (5 POINTS)
- (7) AXLE HUB BEARINGS (1 POINT)

ALIGNMENT SPECIFICATION:
 ZERO: 5 degrees positive, 4/2" dia
 CAMBER: 1/2 degree positive, 4.0" x 1/2
 TOR: 0.8" 1/8" positive, 5.1" 1/32"

APPENDIX B -- FLUID CAPACITIES

These fluid capacities are approximate, and are guidelines only. Actual capacities will vary with the make and model of your vehicle, as well as the component application. We have purposely left a blank column in the chart, so that any differences found in the actual capacity can be recorded for future reference. Always check for proper fluid levels before operating.

Component/System	Initial fill	Service fill		Notes
Rear drive axle	28 pints	26 pints		
Cooling system	7.5 gallons	6.2 gallons		
Hydraulic system	11.5 quarts	9 quarts		
Dash A/C refrigerant	3 lbs.	3 lbs.		Varies with system and application
Transmission	26 quarts	19 quarts		Not including cooler and lines
Engine oil	-----	30 quarts		With filter

APPENDIX C -- CHASSIS FILTERS AND BELTS

COMPONENT	OEM	OTHER	OTHER
Engine oil filter	Caterpillar 1R0739		
Transmission filter	Allison 29526898		
Engine air cleaner element	Farr 998-42-009	Napa 6857	Wicks 546857
Water pump belt	Caterpillar 720244	Napa 25-08755	
Engine drive belt	Napa 25-080700		
Water/fuel separator (Primary fuel filter)	Raycor 200200		
Secondary fuel filter	Caterpillar 1R0751		

Magnum Manufacturing recommends the use of "OEM" or original equipment replacements for all filters and belts when available.

APPENDIX D -- LUBRICATION AND FLUID SPECIFICATIONS

These lubricants and fluids are recommended when operating the vehicle in “normal” conditions. Continuous operation of the vehicle in extreme cold environments (below 10 degrees F), or in extreme hot conditions (over 110 degrees F) may necessitate the use of a different fluid in some components.

When selecting fluids and lubricants for your vehicle, read the container label looking for the specification as shown in the following chart:

Empire CAT 2-7-02 → *75 90 SYNTHETIC oil only Duff - Do NOT MIX*

Component/System	Fluid/Lubricant Specification
Rear drive axle	85W/140 gear oil meeting/exceeding MIL-L-2105D or MIL-PRF-2105-E
Cooling system ³	Mixture of 50% low silicate coolant meeting ASTM D4985 and 50% distilled or de-ionized water. Add supplemental coolant additive to maintain 3 to 6% concentration.
Hydraulic system	DEXRON II or DEXRON III transmission fluid
Fuel ⁵	No. 2-D low sulfur (less than 0.05%) diesel fuel. No. 1 grades are acceptable for cold weather use.
Brake fluid	DOT 3 brake fluid only
Dash A/C refrigerant	R134a refrigerant
Front axle hub lubricant	EP-SAE 90 gear oil
Transmission ⁴	DEXRON III transmission fluid
Brake caliper rails	Silicone lubricant grease
Chassis grease	E.P. (extreme pressure) grease meeting N.G.L.I. grade 2 specifications with 3 to 5% molybdenum disulfide (moly).
Engine oil ⁵	SAE 15W40 meeting API CG-4 (preferred) or CF-4 classification

³ Refer to the Caterpillar Operation & Maintenance Manual for more information.

⁴ Refer to the Allison Transmission Operator’s Manual for more information.

APPENDIX E -- RECOMMENDED TIRE INFLATION PRESSURES

TOYO TIRE SIZE- 255/70R 22.5 (Zanzibar)

PSI	70	75	80	85	90	95	100	105	110	115
SINGLE	3525	3750	3970	4190	4410	4540	4805	4940	5205	5510
DUAL	3195	3415	3640	3860	4080	4190	4410	4540	4805	5070

GOODYEAR TIRE SIZE- 245/75R 22.5 (Cheetah)

PSI	70	75	80	85	90	95	100	105	110
SINGLE	3470	3645	3860	3980	4140	4300	4455	4610	4675
DUAL	3260	3425	3640	3740	3890	4080	4190	4335	4410

PSI- POUNDS PER SQUARE INCH (COLD PRESSURE)

Dual and single weights are the actual weight carried by each tire. Weigh the axle and divide the weight by the number of tires on that axle to determine the weight carried by the tire.

EXAMPLE: A vehicle with 255/70R22.5 tires has a front axle weight of 7,856 pounds, and a rear axle weight of 16,840 pounds. The weight carried by each of the front tires is half of the axle weight, or 3,928 pounds. Looking at the chart, the proper inflation pressure for the front tires would be about 80 psi. The rear axle weight is distributed on two sets of duals, or four tires. Dividing the rear axle weight of 16,840 pounds by four results in a tire load of 4,210 pounds for each of the rear tires. Looking at the chart, the inflation pressure for the rear tires would be about 85 psi.

APPENDIX F -- TYPICAL CHASSIS SERVICE CENTER

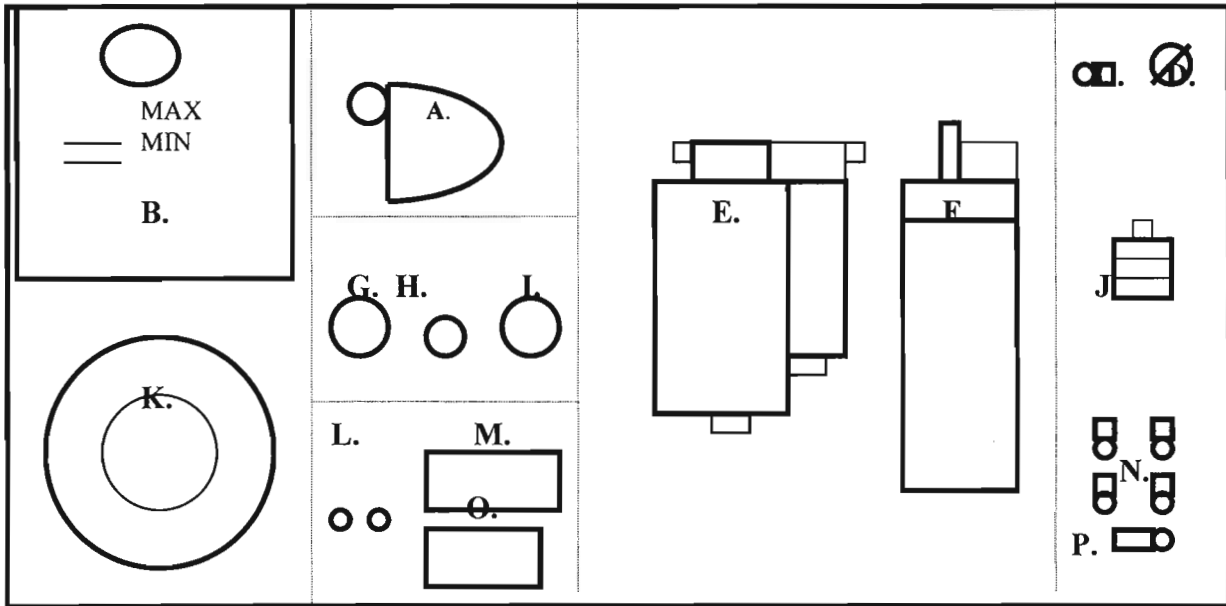

TYPICAL CHASSIS SERVICE CENTER. Present on some models. Components may vary depending on options and chassis model.

- A. Retractable trouble light
- B. Hydraulic fluid reservoir (power steering)
- C. Engine oil dipstick
- D. Transmission fluid dipstick/fill
- E. Water/fuel separator (primary fuel filter)
- F. Secondary fuel filter
- G. Engine oil pressure gauge
- H. Engine diagnostic connector
- I. Engine coolant temperature gauge
- J. Air filter restriction indicator
- K. Paper towels
- L. Engine start and stop switches (configuration may vary with model)
- M. Leveling system control pad and warning lights (not on all models)
- N. Air reservoir bleeder valves (not on all models)
- O. Water/fuel separator control panel (not on all models)
- P. Quick disconnect air coupler (not on all models)

APPENDIX G -- ENGINE WILL NOT START TROUBLESHOOTING

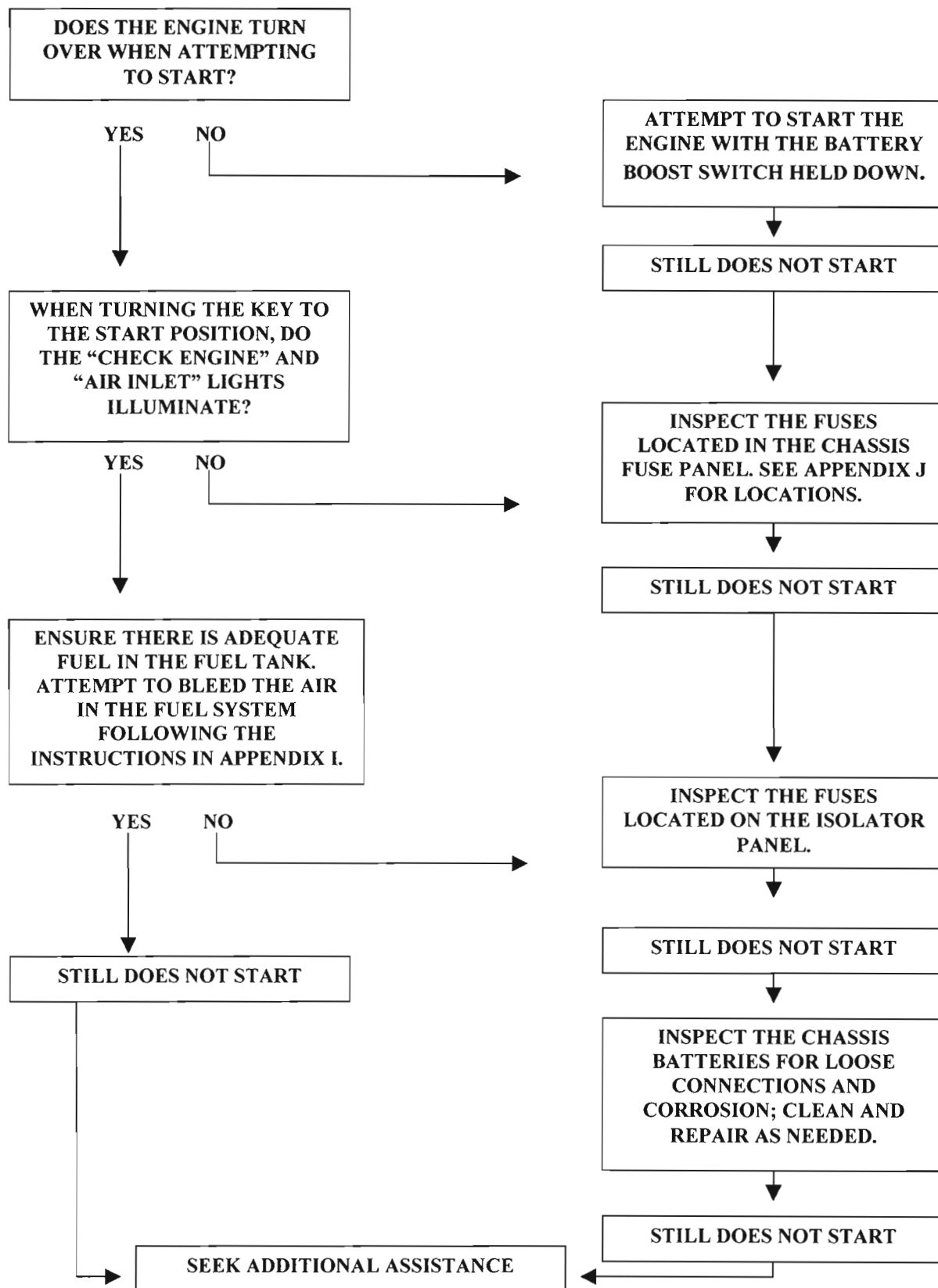

APPENDIX H -- FUEL SYSTEM AIR BLEEDING

Use this procedure when it is suspected that the fuel system has large quantities of air in it. This would be in the event the fuel tank empties while operating the vehicle. In the event that small quantities of air are in the system, the procedures outlined in the section covering fuel filter replacement will be sufficient to bleed the system.

The most important item to remember when bleeding the fuel system is that the air in the system needs to go somewhere. A check valve located at the fuel return on the engine will prevent the air and fuel in the system from returning to the fuel tank *unless the engine is cranked while bleeding*. When bleeding the fuel system, either open a bleed valve in the fuel system, or crank the engine. Go through the following steps to bleed the fuel system:

1. Ensure that there is sufficient fuel in the fuel tank.

WARNING

Crank the engine for 15 seconds. Let the starter motor cool for 2 minutes before the next attempt. Constant use of the starter may cause failure.

For manual priming fuel/water separators:

1. Locate the fuel/water separator on the service center. Loosen the vent plug located on the upper right side of the filter head.
2. Operate the priming pump located on the filter head until only fuel purges at the vent plug. Close the vent plug.
3. Continue to operate the fuel priming pump until it becomes firm. Attempt to start the engine.
4. Continue to operate the priming pump while cranking the engine. If the engine fails to start after 5 cranking cycles of 15 seconds seek additional service. Once the engine starts, it may run rough until all of the air is out of the system. It may be necessary to continue operating the priming pump while the engine is running until all air is out of the system.

For electronic priming fuel/water separators:

1. Locate the fuel/water separator and the control panel on the service center. Remove the cap for the Shrader valve at the top of the fuel/water separator.
2. Activate the "AIR PURGE" switch on the control panel by pressing and releasing the switch. Depress the inner pin on the Shrader valve to open it, and hold until fuel comes out of the valve. If the air purge system completes its cycle prior to fuel coming out of the valve, reactivate it by pressing and releasing the switch again.
3. After the fuel from the tank has reached the fuel/water separator and flows from the Shrader valve, replace the cap for the Shrader valve on the separator.
4. With the ignition key in the "ON" position, reactivate the air purge system. After the system has run for approximately 30 seconds, attempt to start the engine.
5. Repeat step 5 until five air purge cycles has been completed, or until the engine starts. If the engine fails to start after 5 cycles, seek additional service. Once the engine starts, it may run rough until all of the air is run out of the system. It may be necessary to run the engine at fast idle until it runs smoothly.

APPENDIX I -- CHASSIS FUSE PANEL

Located in battery compartment

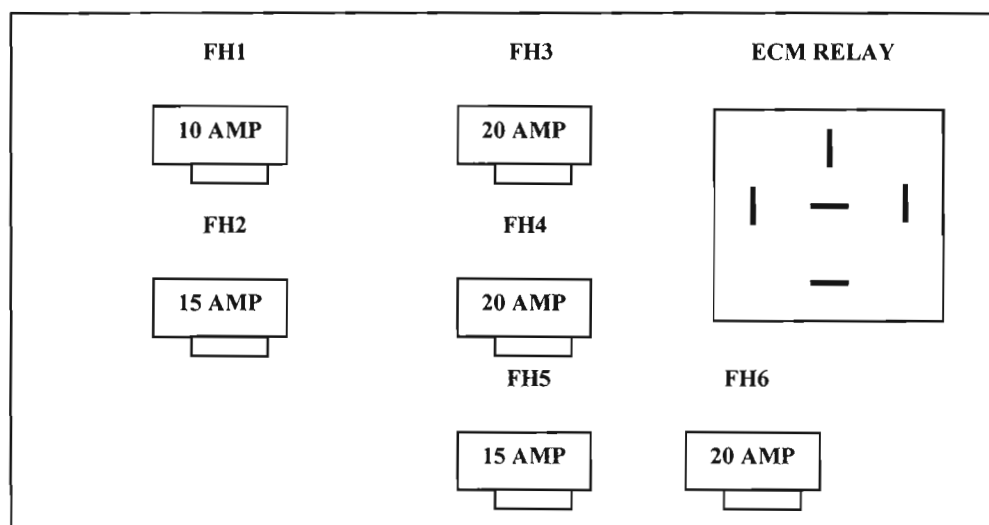

FUSE DESCRIPTIONS

FH1- Chassis solar panel

FH2- Coach solar panel

FH3- Transmission electronics

FH4- ECM Event Recorder- provides constant power to engine electronics

FH5- Service center- provides power to service center gauges, etc.

FH6- ECM relay - power for ECM relay

ECM RELAY- Provides ignition power to engine electronics

APPENDIX J -- MAIN DRIVE BELT DIAGRAM

NOT TO SCALE

